

TX-28/25XD60C Service Manual

Safety

Specifications

Parts List

Service Information

Adjustments

Self Check

Service Hints

Mechanical View

Disassembly

Location of Controls

Waveforms

Block Diagrams

Schematic Diagrams

PCB Views

Service Support

Service and repair of this product is supported by Panasonic's LUCI interface.

This interface provides a link between the TV and a standard PC to allow a number of diagnostic and control functions to be performed.

For more details contact your local Panasonic company.

BACK

EXIT

Video / Audio

Control



BACK

B2 - PCB

D - PCB

E - PCB

F2 - PCB

H - PCB

Y - PCB

B2 - Schematic

D - Schematic

E - Schematic

F2 - Schematic

H - Schematic

M3 - Schematic

Y - Schematic



BACK



BACK

Service Manual



Colour Television

TX-28XD60C TX-25XD60C

EURO-3H Chassis

SPECIFICATIONS

(Information in brackets {} refers to TX-25XD60C)

Power Source :	220-240V AC, 50Hz
Power Consumption :	155W {150W}
Standby Power Consumption :	1W
Aerial Impedance :	75Ω unbalanced, Coaxial Type
Receiving System :	PAL-I, B, G, D, K, H, PAL 60, SECAM B, G, D, K, L/L' MNTSC, NTSC (AV Only)

Receiving Channels :	
VHF E2 – E12	VHF H1 – H2 (ITALY)
VHF A – H (ITALY)	VHF R1 – R2
VHF R3 – R5	VHF R6 – R12
UHF E21 – E69	CATV (S01 – S05)
CATV S1 – S10 (M1 – M10)	CATV S11 – S20 (U1 – U10)
CATV S21 – S41 (HYPERBAND)	

Intermediate Frequency :	
Video	38.9 MHz, 34 MHz
Sound	32.9 MHz, 33.4 MHz, 34.05 MHz 33.16 MHz, 32.4 MHz, 40.4 MHz
Colour	34.47 MHz, 34.5 MHz, 34.65 MHz

Video / Audio Terminals :

AUDIO MONITOR OUT	Audio(RCA x2)	500mV rms, 1kΩ
AV1 IN	Video (21 pin) Audio (21 pin) RGB (21 pin)	1V p-p 75Ω 500mV rms 10kΩ
AV1 OUT	Video (21 pin) Audio (21 pin)	1V p-p 75Ω 500mV rms 1kΩ
AV2 IN	Video (21 pin) Audio (21 pin) S-Video IN (21 pin)	1V p-p 75Ω 500mV rms 10kΩ Y : 1V p-p 75Ω C : 0.3V p-p 75Ω
AV2 OUT	Video (21 pin) Audio (21 pin)	1V p-p 75Ω 500mV rms 1kΩ
AV3 IN	Audio (RCA x2) Video (RCA x1)	500mV rms, 10kΩ 1V p-p 75Ω

High Voltage : 28.5kV ± 1kV (zero beam current)

Picture Tube : A66ECF61X71 66 cm
{A59ECF50X71 59 cm}

Audio Output :

Speaker 2 x 20W (Music Power)
8 Ω Impedance

Headphones 8 Ω Impedance

Accessories supplied : Remote Control
2 x R6 (UM3) Batteries

Dimensions :

Height :	596.5 mm {550mm}
Width :	778 mm {730mm}
Depth :	481.5 mm {479mm}

Net Weight : 35kg {30kg}

Specifications are subject to change without notice.
Weight and dimensions shown are approximate.

TECHNISCHE DATEN

(Werte in Klammern gelten {} nur für TX-25XD60C)

Netzspannung :	220-240V AC, 50Hz
Leistungsaufnahme :	155W {150W}
Standby Leistungsaufnahme :	1W
Antennenimpedanz :	75Ω asymmetrisch, Koaxial-Typ
Empfangssystem :	PAL-I, B, G, D, K, H, PAL 60, SECAM B, G, D, K, L/L' MNTSC, NTSC (nur AV Eingang)

Empfangsbereiche :

VHF E2 – E12	VHF H1 – H2 (ITALY)
VHF A – H (ITALY)	VHF R1 – R2
VHF R3 – R5	VHF R6 – R12
UHF E21 – E69	CATV (S01 – S05)
CATV S1 – S10 (M1 – M10)	CATV S11 – S20 (U1 – U10)
CATV S21 – S41 (HYPERBAND)	

Zwischenfrequenz :

Video	38.9 MHz, 34 MHz
Sound	32.9 MHz, 33.4 MHz, 34.05 MHz 33.16 MHz, 32.4 MHz, 40.4 MHz
Colour	34.47 MHz, 34.5 MHz, 34.65 MHz

Video / Audio Anschlüsse :

AUDIO MONITOR OUT	Audio(RCA x2)	500mV rms, 1kΩ
AV1 EINGANG	Video (21 pin) Audio (21 pin) RGB (21 pin)	1V p-p 75Ω 500mV rms 10kΩ
AV1 AUSGANG	Video (21 pin) Audio (21 pin)	1V p-p 75Ω 500mV rms 1kΩ
AV2 EINGANG	Video (21 pin) Audio (21 pin) S-Video IN (21 pin)	1V p-p 75Ω 500mV rms 10kΩ Y : 1V p-p 75Ω C : 0.3V p-p 75Ω
AV2 AUSGANG	Video (21 pin) Audio (21 pin)	1V p-p 75Ω 500mV rms 1kΩ
AV3 EINGANG	Audio (RCA x2) Video (RCA x1)	500mV rms, 10kΩ 1V p-p 75Ω

Hochspannung : 28.5kV ± 1kV (bei Nullstrahlstrom)

Bildrohre : A66ECF61X71 66 cm
{A59ECF50X71 59 cm}

Ton Ausgangsleistung : 2 x 20W (Musikleistung)
Lautsprecher 8 Ω Impedanz

Kopfhörer 8 Ω Impedanz

Mittel, Zubehör : Fernbedienung
2 x R6 (UM3) Batterien

Abmessungen :

Höhe :	596.5 mm {550mm}
Breite :	778 mm {730mm}
Tiefe :	481.5 mm {479mm}

Gewicht : 35kg {30kg}

Änderungen der technischen Daten vorbehalten.
Gewichte und Abmessungen sind Näherungsangaben.

CONTENTS

SAFETY PRECAUTIONS
SERVICE HINTS
SERVICE MODE
ADJUSTMENT PROCEDURE
SELF CHECK
ALIGNMENT SETTINGS
WAVEFORM PATTERN TABLE
BLOCK DIAGRAMS
PARTS LOCATION
REPLACEMENT PARTS LIST
CONDUCTOR VIEWS
SCHEMATIC DIAGRAMS

SAFETY PRECAUTIONS

GENERAL GUIDE LINES

1. It is advisable to insert an isolation transformer in the AC supply before servicing a hot chassis.
2. When servicing, observe the original lead dress in the high voltage circuits. If a short circuit is found, replace all parts which have been overheated or damaged by the short circuit.
3. After servicing, see that all the protective devices such as insulation barriers, insulation papers, shields and isolation R-C combinations are correctly installed.
4. When the receiver is not being used for a long period of time, unplug the power cord from the AC outlet.
5. Potentials as high as 29.5kV are present when this receiver is in operation. Operation of the receiver without the rear cover involves the danger of a shock hazard from the receiver power supply. Servicing should not be attempted by anyone who is not familiar with the precautions necessary when working on high voltage equipment. Always discharge the anode of the picture tube to the chassis before handling the tube.
6. After servicing make the following leakage current checks to prevent the customer from being exposed to shock hazards.

LEAKAGE CURRENT COLD CHECK

1. Unplug the AC cord and connect a jumper between the two prongs of the plug.
2. Turn on the receiver's power switch.
3. Measure the resistance value with an ohmmeter, between the jumpered AC plug and each exposed metallic cabinet part on the receiver, such as screw heads, aerials, connectors, control shafts etc. When the exposed metallic part has a return path to the chassis the reading should be between 4M ohm and 20M ohm. When the exposed metal does not have a return path to the chassis the reading must be infinite.

INHALT

SICHERHEITSVORKEHRUNGEN
SERVICE HINWEISE
ABGLEICHVERFAHREN
ABGLEICH
SELF CHECK
ABGLEICHTABELLE
SIGNALE TABELLE
SCHALTBILD BLOCK
EXPLOSIONSZEICHNUNG
ERSATZTEILLISTE
ANSICHT DER LEITERBAHNEN
SCHALTBILD SCHEMA

SICHERHEITSVORKEHRUNGEN

ALLGEMEINE RICHTLINIEN

1. Es ist empfehlenswert einen Trenntransformator in die Stromversorgung zu schalten, bevor Reparaturen an einem Gerät vorgenommen werden, dessen Chassis unter Spannung steht.
2. Bei der Durchführung von Servicearbeiten dürfen die ursprünglichen Kabelanschlüsse nicht vertauscht werden. Dies gilt insbesondere für die Anschlüsse im Hochspannungsteil. Hat sich ein Kurzschluß ereignet, dann sind alle Teile, an denen Spuren von Überhitzung sichtbar sind, auszuwechseln.
3. Nach Beenden der Servicearbeiten ist sicherzustellen, daß alle Sicherheitsvorrichtungen, wie Isolationsstege, Isolationspapiere, Abschirmungen und Isolations R-C Glieder wieder richtig eingesetzt sind.
4. Wenn der Fernseher während längerer Zeit nicht in Betrieb gesetzt wird, sollte der Netzstecker aus der Netzsteckdose gezogen werden.
5. Im Betrieb sind Spannungen bis zu 29.5kV in diesem Gerät vorhanden. Die Inbetriebnahme des Fernsehers ohne aufgesetzte Rückwand bringt die Gefahr eines elektrischen Schlages von der Fernseher – Stromversorgung mit sich. Servicearbeiten sollten daher auch nie durch Personen versucht werden, die nicht in vollem Umfang mit den Sicherheitsvorkehrungen beim Umgang mit Hochspannungsgeräten vertraut sind. Vor der Handhabung mit der Bildröhre ist die Anode der Bildröhre immer an dem Empfängerchassis zu entladen.
6. Nach Beenden der Servicearbeiten sind die folgenden Kriechstrom-Prüfungen durchzuführen, um den Kunden vor der Gefahr eines elektrischen Schlages zu schützen.

MESSUNG DES ISOLATIONSWIDERSTANDES IM ABGESCHALTETEN ZUSTAND

1. Den Netzstecker aus der Netzsteckdose ziehen und die beiden Steckerstifte kurzschließen.
2. Den Geräteschalter des Fernsehgerätes einschalten.
3. Mit einem Ohmmeter den Widerstandswert zwischen dem überbrückten Netzkabelstecker und jedem zugänglichen Metallteil am Gehäuse des Fernsehgerätes, wie Schraubenköpfe, Antennen, Achsen der Regler, Griffassungen usw. messen. Wenn ein zugängliches Metallteil keine Rückleitung zum Chassis hat, muß die Anzeige unendlich betragen.

LEAKAGE CURRENT HOT CHECK

1. Plug the AC cord directly into the AC outlet. Do not use an isolation transformer for this check.
2. Connect a 2kΩ 10W resistor in series with an exposed metallic part on the receiver and an earth such as a water pipe.
3. Use an AC voltmeter with high impedance to measure the potential across the resistor.
4. Check each exposed Metallic part and check the voltage at each point.
5. Reverse the AC plug at the outlet and repeat each of the above measurements.
6. The potential at any point should not exceed 1.4 Vrms. In case a measurement is outside the limits specified, there is a possibility of a shock hazard, and the receiver should be repaired and rechecked before it is returned to the customer.

MESSUNG DES KRIECHSTROMS IM EINGESCHALTETEN ZUSTAND

1. Den Netzstecker direkt in eine Netsteckdose stecken. Für diese Messung keinen Trenntransformator verwenden.
2. Einen 2k Ω / 10W–Widerstand in Serie mit einem von außen zugänglichen Metallteil am Fernsehgerät und einer guten, Erdung z.B Wasserleitung, anschließen.
3. Ein Wechselstrom–Voltmeter mit einem Meßbereich von 1000 Ohm.Volt oder größer verwenden, um die Spannung über den Widerstand zu messen.
4. Jedes zugängliche Metallteil prüfen, und an jedem Punkt dies Spannung messen.
5. Den Netzstecker umgekehrt in die Steckdose stecken und jede der obigen Messungen wiederholen.
6. Die Spannung darf an keinem der Punkte 1.4V eff. überschreiten. Wird dieser Wert nicht eingehalten, besteht die Gefahr eines elektrischen Schlages, und das Fernsehgerät sollte daher repariert und nachgeprüft werden, bevor es an den Kunden zurückgegeben wird.

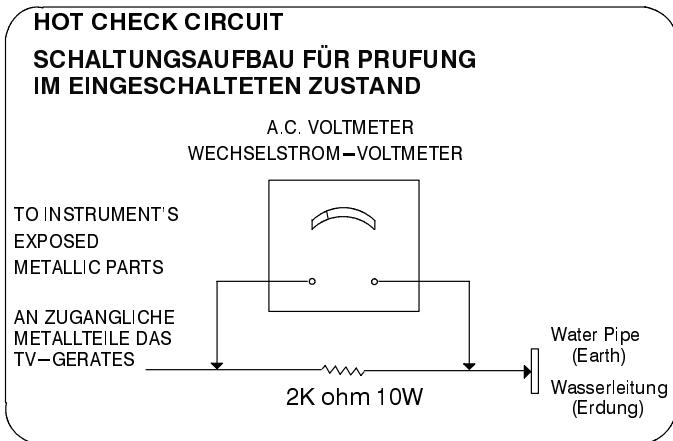

Fig.1.
Abb.1.

X–RADIATION WARNING

1. The potential sources of X–Radiation in TV sets are the high voltage section and the picture tube.
2. When using a picture tube test jig for service ensure that the jig is capable of handling 29.5kV without causing X–Radiation.

NOTE : It is important to use an accurate periodically calibrated high voltage meter

1. Set the brightness to minimum.
2. Measure the high voltage. The meter should indicate 28.5kV ± 1kV if the meter indication is out of tolerance, immediate service and correction is required to prevent the possibility of premature component failure.
3. To prevent any X–Radiation possibility, it is essential to use the specified tube.

RÖNTGENSTRAHLUNG ACHTUNG :

1. Potentielle Quellen von Röntgenstrahlung in Fernsehgeräten sind das Hochspannungsteil und die Bildröhre.
2. Bei Verwendung eines Bildröhren–Prüfgerätes für den Service ist sicherzustellen, daß es für die Belastung von 29.5kV geeignet ist, ohne daß eine Röntgenstrahlung verursacht wird.

ANMERKUNG : Es ist wichtig, daß ein präzises, regelmäßig geprüftes Voltmeter verwendet wird.

1. Helligkeit auf Minimum stellen.
2. Die Hochspannung messen. Die Anzeige des Instrumentes sollte 28.5kV ± 1kV Falls die Anzeige diese Toleranzgrenzen überschreitet, ist die sofortige Behebung nötig, um die Möglichkeit vorzeitigen Komponentenausfalls zu verhüten.
3. Um die Möglichkeit von Röntgenstrahlung zu begrenzen, ist es wichtig, daß nur die vorgeschriebene Bildröhre verwendet wird.

SERVICE HINTS

HOW TO REMOVE THE REAR COVER

1. Remove the 9 screws (A) as shown in Fig.2/Fig.3.

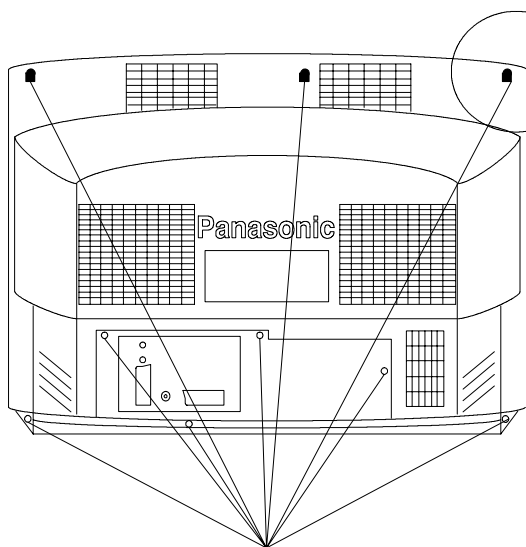

SCREWS A
SCHRAUBEN A

Fig. 2.
Abb. 2.

SERVICE HINWEISE

ENTFERNEN DER GERÄTERÜCKWAND

1. Die 9 Schrauben (A) entfernen, siehe Abb.2/Abb.3.

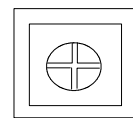

SCREW
SCHRAUBEN

Fig. 3.
Abb. 3.

LOCATION OF CONTROLS

LAGE DER EINSTELLREGLER

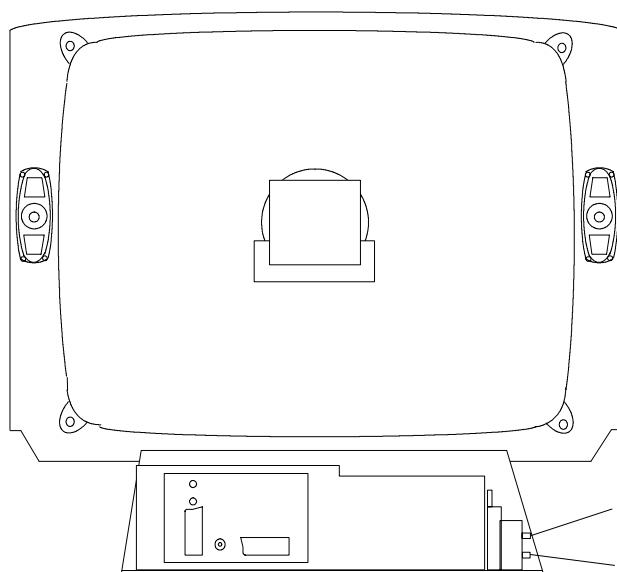

E P.C.B.

Fig. 4.
Abb. 4.

FOCUS
FOKUSREGLER

SCREEN
SCHIRMGITTERREGLER

SERVICE MODE

The remote control is used for entering and storing adjustments, with the exception of cut-off adjustments which must always be done prior to service adjustment. Perform adjustments in accordance with screen display. The display on the screen also specifies the CCU variants as well as the approx. setting values. The adjustment sequence for the service mode is indicated below.

1. Set the Bass to maximum position, set the Treble to minimum position, press the Reveal button on the remote control and at the same time press the Volume down on the customer controls at the front of the TV, this will place the TV into the Service Mode.
2. Press the RED / GREEN buttons to step down / up through the functions.
3. Press the YELLOW / BLUE buttons to alter the function values.
4. Press the STORE button on the preset panel after each adjustment has been made to store the required values.
5. To exit the Service Mode press the Normalisation button.

NOTE: This TV also has the option of using a Memory Pack which enables you to copy the preset TV channels and analogue levels into the Memory Pack and then upload them onto another EURO-3H TV set.

USING THE MEMORY PACK

TV to Memory Pack process

1. Plug the memory pack into the lower of the two 21 pin terminals at the back of the TV and switch the TV on. If the TV has only one 21 pin connector then this will be able to accept the memory pack.
2. Go into the Service Mode as explained above. The screen will show:—

Program
External>>TV

3. Press the blue button on the remote control. The screen will show:—

Program
TV>>External

4. Press the STORE button on the TV. The screen will show:—

Storing

5. All the tuning information stored inside the TV will now be transferred to the Memory Pack. This process will take 2–3 minutes to complete and when finished the screen will show:—

OK!

Memory Pack to TV Process

1. Plug the memory pack into the lower of the two 21 pin terminals at the back of the TV and switch the TV on. If the TV has only one 21 pin connector then this will be able to accept the memory pack.
2. Go into the Service Mode as explained above. The screen will show:—

Program
External>>TV

3. Press the STORE button on the TV. The screen will show:—

Loading

4. All the tuning information stored inside the Memory Pack will now be transferred to the TV. This process will take 2–3 minutes to complete and when finished the screen will show:—

OK!

5. The tuning information from the Memory Pack has now been copied into the TV
6. To exit from the Service Mode switch off the TV.
7. The process has now been completed and the Memory Pack can now be removed.

Errors

If an error occurs while using the Memory Pack the TV will detect this and the screen will show:—

Program
Error!

If this happens then switch off the TV and repeat the process that was being used. If the errors continue to occur then check the connectors between the TV and the memory pack and check the 9V battery inside the memory pack.

ABGLEICHVERFAHREN

Die Fernbedienung dient zum Eingeben und Abspeichern der Einstellwerte, mit Ausnahme der Sperrpunkteinstellung, die grundsätzlich vor den hier beschriebenen Einstellungen vorgenommen werden muss. Die Einstellung erfolgt entsprechend dem Bildschirm—Display. Auf dem Bildschirm—Display erscheinen auch die CCU—Varianten sowie die ungefähren Einstellwerte. Die Einstellfolge für den Service—Modus ist nachstehend beschrieben.

- Um in den Service—Mode zu gelangen, gehen sie bitte wie folgt vor.
 - Stellen sie im Toneinstellungs—Menü die Bässe auf Maximum und die Höhen auf Minimum.
 - Halten sie die REVEAL—Taste auf der Fernbedienung gedrückt und drücken zusätzlich die Taste —/v im Bedienteil des TV—Gerätes. Auf dem Bildschirm erscheint die entsprechende Anzeige für den Service—Mode.
- Die einzelnen Funktionen mit Hilfe der ROTEN und GRÜNEN Taste anwählen.
- Mit der GELBEN und BLAUEN Taste die Werte der einzelnen Funktionen ändern.
- Nach jeder Einstellung die Taste STR auf der Fernbedienung oder am Bedienfeld drücken, um die geänderten Werte abzuspeichern.
- Zum Verlassen des Service—Modus die "N"—Taste auf der Fernbedienung drücken

HINWEIS: Dieses FS—Gerät bietet auch die Möglichkeit eines Memory Pack, mit dem Sie die gewählten Fernsehkanäle abspeichern und auf jedes beliebige EURO3H FS—Gerät umkopieren können.

Kopieren der Einstelldaten vom FS—Gerät in das Memory Pack

- Das Memory Pack in die AV2—Buchse an der Rückseite des FS—Gerätes stecken und das Gerät einschalten.
- Wie schon oben beschrieben auf Service—Modus umschalten. Auf dem Bildschirm erscheint:

Program
External>>TV

- Nun die blaue Taste an der Fernbedienung betätigen. Auf dem Bildschirm erscheint:

Program
TV>>External

- Die Taste STORE am Fernseher drücken. Der Bildschirm meldet nun:

Storing

- Die im FS—Gerät abgespeicherten Kanal—Einstelldaten werden nun in das Memory Pack überspielt. bei abgeschlossener Datenübertragung meldet der Bildschirm:

OK!

Kopieren der Einstelldaten vom Memory Pack in das FS—Gerät

- Das Memory Pack in die AV2—Buchse an der Rückseite des FS—Gerätes stecken und das Gerät einschalten.
- Wie schon oben beschrieben auf Service—Modus umschalten. Auf dem Bildschirm erscheint:

Program
External>>TV

- Die Taste STORE am Fernseher drücken. Der Bildschirm meldet nun:

Loading

- Die im Memory Pack abgespeicherten Einstelldaten werden nun in das FS—Gerät überspielt. bei abgeschlossener Datenübertragung meldet der Bildschirm:

OK!

- Die Kanal—Einstelldaten sind damit vom Memory Pack in das FS—Gerät überspielt.
- Zum Verlassen des Service—Modus die "N"—Taste auf der Fernbedienung drücken
- Der Kopiervorgang ist somit abgeschlossen, und das Memory Pack kann von der Steckerleiste abgezogen werden.

Fehler

Falls beim Gebrauch des Memory Packs Fehler auftreten, zeigt das FS—Gerät dies auf dem Bildschirm mit der folgenden Meldung an:

Program
Error!

In diesem Fall muss der Service—Modus durch Drücken der "N"—Taste auf der Fernbedienung verlassen und anschliessend der Vorgang wiederholt werden. Falls weiterhin Fehlermeldungen erscheinen, müssen die Anschlusskontakte zwischen FS—Gerät und Memory Pack sowie die 9V Batterie im Memory Pack kontrolliert werden.

ADJUSTMENT PROCEDURE

Item/Preparation	Adjustments																																																												
Supply Voltage Check 1. Receive a standard test pattern 2. Set the controls: Brightness Minimum Contrast Minimum Volume Minimum	1. Confirm the following voltages. <table style="width: 100%; border-collapse: collapse;"> <thead> <tr> <th colspan="3" style="text-align: left;"><u>E PCB</u></th> <th colspan="3" style="text-align: left;"><u>D PCB</u></th> </tr> </thead> <tbody> <tr> <td>U5B</td> <td>5</td> <td>± 0.5V</td> <td>U5A</td> <td>5.1</td> <td>± 0.12V</td> </tr> <tr> <td>U8A</td> <td>8</td> <td>± 0.5V</td> <td>U5SB</td> <td>5</td> <td>± 0.25V</td> </tr> <tr> <td>U9</td> <td>9</td> <td>± 0.5V</td> <td>TP1</td> <td>15</td> <td>± 0.7V</td> </tr> <tr> <td>U12</td> <td>11.8</td> <td>± 0.5V</td> <td>U16</td> <td>18.2</td> <td>± 0.8V</td> </tr> <tr> <td></td> <td></td> <td></td> <td>U22</td> <td>22.5</td> <td>± 1V</td> </tr> <tr> <td></td> <td></td> <td></td> <td>U38</td> <td>39</td> <td>± 1V</td> </tr> <tr> <td></td> <td></td> <td></td> <td>TP2</td> <td>54</td> <td>± 2.5V</td> </tr> <tr> <td></td> <td></td> <td></td> <td>U150</td> <td>150</td> <td>± 1V</td> </tr> <tr> <td></td> <td></td> <td></td> <td>U200</td> <td>200</td> <td>± 10V</td> </tr> </tbody> </table>	<u>E PCB</u>			<u>D PCB</u>			U5B	5	± 0.5V	U5A	5.1	± 0.12V	U8A	8	± 0.5V	U5SB	5	± 0.25V	U9	9	± 0.5V	TP1	15	± 0.7V	U12	11.8	± 0.5V	U16	18.2	± 0.8V				U22	22.5	± 1V				U38	39	± 1V				TP2	54	± 2.5V				U150	150	± 1V				U200	200	± 10V
<u>E PCB</u>			<u>D PCB</u>																																																										
U5B	5	± 0.5V	U5A	5.1	± 0.12V																																																								
U8A	8	± 0.5V	U5SB	5	± 0.25V																																																								
U9	9	± 0.5V	TP1	15	± 0.7V																																																								
U12	11.8	± 0.5V	U16	18.2	± 0.8V																																																								
			U22	22.5	± 1V																																																								
			U38	39	± 1V																																																								
			TP2	54	± 2.5V																																																								
			U150	150	± 1V																																																								
			U200	200	± 10V																																																								

ABGLEICH

Vorbereitung	Abgleich																																																												
Prüfen der Versorgungsspannung 1. Testbild empfangen. 2. Helligkeit auf Minimum Kontrast auf Minimum Lautstärke auf Minimum	1. Folgende Spannungen sind zu überprüfen : <table style="width: 100%; border-collapse: collapse;"> <thead> <tr> <th colspan="3" style="text-align: left;"><u>E PCB</u></th> <th colspan="3" style="text-align: left;"><u>D PCB</u></th> </tr> </thead> <tbody> <tr> <td>U5B</td> <td>5</td> <td>± 0.5V</td> <td>U5A</td> <td>5.1</td> <td>± 0.12V</td> </tr> <tr> <td>U8A</td> <td>8</td> <td>± 0.5V</td> <td>U5SB</td> <td>5</td> <td>± 0.25V</td> </tr> <tr> <td>U9</td> <td>9</td> <td>± 0.5V</td> <td>TP1</td> <td>15</td> <td>± 0.7V</td> </tr> <tr> <td>U12</td> <td>11.8</td> <td>± 0.5V</td> <td>U16</td> <td>18.2</td> <td>± 0.8V</td> </tr> <tr> <td></td> <td></td> <td></td> <td>U22</td> <td>22.5</td> <td>± 1V</td> </tr> <tr> <td></td> <td></td> <td></td> <td>U38</td> <td>39</td> <td>± 1V</td> </tr> <tr> <td></td> <td></td> <td></td> <td>TP2</td> <td>54</td> <td>± 2.5V</td> </tr> <tr> <td></td> <td></td> <td></td> <td>U150</td> <td>150</td> <td>± 1V</td> </tr> <tr> <td></td> <td></td> <td></td> <td>U200</td> <td>200</td> <td>± 10V</td> </tr> </tbody> </table>	<u>E PCB</u>			<u>D PCB</u>			U5B	5	± 0.5V	U5A	5.1	± 0.12V	U8A	8	± 0.5V	U5SB	5	± 0.25V	U9	9	± 0.5V	TP1	15	± 0.7V	U12	11.8	± 0.5V	U16	18.2	± 0.8V				U22	22.5	± 1V				U38	39	± 1V				TP2	54	± 2.5V				U150	150	± 1V				U200	200	± 10V
<u>E PCB</u>			<u>D PCB</u>																																																										
U5B	5	± 0.5V	U5A	5.1	± 0.12V																																																								
U8A	8	± 0.5V	U5SB	5	± 0.25V																																																								
U9	9	± 0.5V	TP1	15	± 0.7V																																																								
U12	11.8	± 0.5V	U16	18.2	± 0.8V																																																								
			U22	22.5	± 1V																																																								
			U38	39	± 1V																																																								
			TP2	54	± 2.5V																																																								
			U150	150	± 1V																																																								
			U200	200	± 10V																																																								

SELF CHECK

Self check is used to automatically check the Bus lines and Hexadecimal code of the TV set.

To enter the Self Check mode press Function down button, on the Preset Panel, at the same time pressing the Status button, on the Remote Control, and the screen will show: –

When exiting Self Check the customer settings will return to factory setup.

SELBSTDIAGNOSE

1) Die Selbstdiagnose dient zum automatischen Prüfen der Bus-Leitungen sowie des Hexadezimalcodes des FS-Geräts. Zum Umschalten auf Selbstdiagnose nach dem Drücken der "F"-Taste die "Lautstärke Minus" Taste am Bedienfeld des FS-Geräts und gleichzeitig die Taste "Status" an der Fernbedienung drücken; auf dem Bildschirm erscheint hierauf: –

2) Nach der Selbstdiagnose wird das Gerät automatisch auf sämtliche werksseitigen Standardeinstellungen zurückgesetzt: –

						Hex codes		
0 — ok	Test Byte	8 — ok	Col Decoder (M)	16 — --	Col Decoder (P)	09 73 A4 BC BB BF 33		
1 — ok	Lst Power	9 — ok	Clock generator	17 — --	Q – PIP			
2 — ok	U5 Det	10 — ok	V – Processor	18 — ok	Not Used			
3 — ok	Protector	11 — ok	DFU	19 — ok	Not Used			
4 — ok	Not Used	12 — ok	Display Processor	20 — ok	EAROM			
5 — ok	Not Used	13 — ok	RGB Processor	21 — ok	Audio Matrix			
6 — ok	Not Used	14 — ok	Deflection IC	22 — ok	Video Matrix			
7 — ok	Not Used	15 — ok	MSP	23 — ok	Tuner			

If the CCU ports have been checked and found to be incorrect or not located then "--" will appear in place of "OK".

Wenn der Hauptprozessor (CCU) an den Anschlüssen einen Fehler erkennt, oder der entsprechende Anschluss nicht belegt ist, zeigt die entsprechende Position -- anstelle von OK an.

Alignment Settings

(The figures used below are nominal and used for representative purposes only)

The remote control is used for entering and storing adjustments. The adjustment sequence for the service mode is indicated below.

1. Set the Bass to maximum position, set the Treble to minimum position, press and hold the Reveal button on the remote control and at the same time press the --/v button on the customer controls at the front of the TV, this will place the TV into the Service Mode.
2. Press the RED / GREEN buttons to step up / down through the functions.
3. Press the YELLOW / BLUE buttons to alter the function values.
4. Press the STORE button after each adjustment has been made to store the required values.
5. To exit the Service Mode press the Normalisation button.

Alignment Function		Settings / Special features
Vertical amplitude	V-AMP 038	Optimum setting
Vertical linearity	V-LIN 022	
V-Pos.	V-POS 005	Optimum setting
Horizontal amplitude	H-AMP 043	Optimum setting
Horizontal position	H-POS 035	
EW-amplitude	E/W-AMP 1 020	Optimum setting
EW-amplitude	E/W-AMP 2 015	Optimum setting
Trapezium-comp	TRAPEZ-1 004	Optimum setting
Vert. DC.	VERT. D.C. 008	Not to be adjusted.
Text Position	TEXT POSITION 060	Optimum setting
Cutoff	---	Enter Service Mode and step through to Cutoff, connect an oscilloscope to the Blue Cathode and adjust the screen VR of the FBT to get $150 \pm 5V$ at the base of the Cutoff pulse.
Cutoff RGB	CUTOFF RGB 032 032 032	Press the GREEN button to step through these settings. Adjust for optimum.
White RGB	WHITE RGB 032 032 032	Press the GREEN button to step through these settings. Adjust for optimum.
Sub Brightness	SUB BRIGHT 000	Optimum setting

Abgleichtabelle

(Die angegebenen Werte sind Mittelwerte und Können individuell nach oben oder unten nach dem korrekten Abgleich abweichen)

Die Fernbedienung dient zum Eingeben und Abspeichern der Einstellwerte. Die Einstellfolge für den Service-Modus ist nachstehend beschrieben.

1. Den Tiefenregler auf Höchststellung und den Höhenregler auf Mindeststellung stellen. Nachdem die F-Taste am Bedienfeld des FS-Gerätes gedrückt wurde, die Die Taste "Lautstärke Minus" am FS-Gerät drücken und gleichzeitig die Taste "Reveal" auf der Fernbedienung betätigen. Hierdurch wird das FS-Gerät auf Service-Modus geschaltet.
2. Die einzelnen Funktionen mit Hilfe der ROTEN und GRÜNEN Taste anwählen.
3. Mit der GELBEN und BLAUEN Taste die Werte der einzelnen Funktionen ändern.
4. Nach jeder Einstellung die Taste STR auf der Fernbedienung oder am Bedienfeld drücken, um die geänderten Werte abzuspeichern.
5. Zum Verlassen des Service-Modus die "N"-Taste auf der Fernbedienung drücken

Abgleichfunktion		Einstellung/Besondere Merkmale
Vertikale Amplitude	V-AMP 038	Optimale Einstellung
Vertical linearität	V-LIN 022	
V-Pos.	V-POS 005	Optimale Einstellung
Horizontale Amplitude	H-AMP 043	Optimale Einstellung
Horizontale position	H-POS 035	
OW-amplitude	E/W-AMP 1 020	Optimale Einstellung
OW-amplitude	E/W-AMP 2 015	Optimale Einstellung
Trapez-Kompensation	TRAPEZ-1 004	Optimale Einstellung
Vert. DC.	VERT. D.C. 008	Nicht einstellen
Text Position	TEXT POSITION 060	Optimale Einstellung
Cutoff	---	Den Service Mode aktivieren und auf Cutoff gehen. Oscilloscope an Blaukathode anschliessen und mit dem "Screen" -Regler am Zeilentrafo die untere Spitze des Cutoff-Pulses auf 150V +/- 5V einstellen.
Cutoff RGB	CUTOFF RGB 032 032 032	Die Einstellungen mit Hilfe der GRÜNEN Taste anwählen. Optimale Einstellung.
White RGB	WHITE RGB 032 032 032	Die Einstellungen mit Hilfe der GRÜNEN Taste anwählen. Optimale Einstellung.
Grundhelligket	SUB BRIGHT 000	Optimale Einstellung

WAVEFORM PATTERN TABLE

NOTES: All waveforms have been taken using a standard colour bar pattern.

HINWEIS: Alle oszillogramme wurden unter Verwendung des Standard Farbbalken Testbildes aufgenommen.

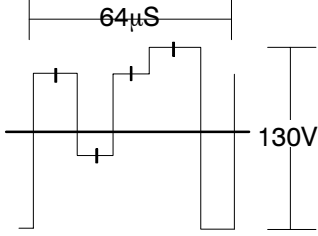
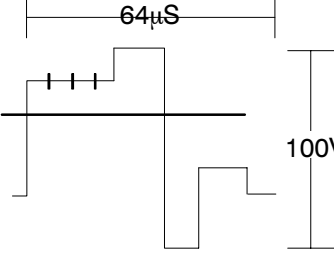
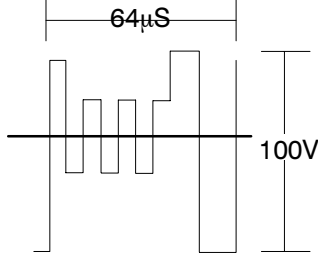
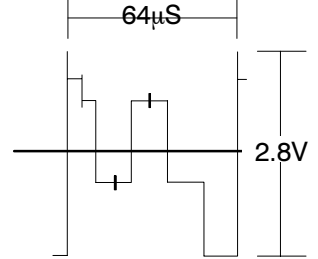
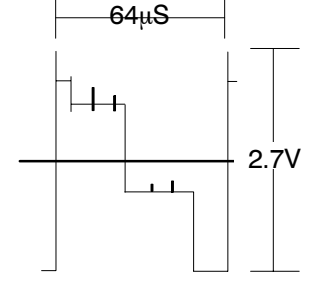
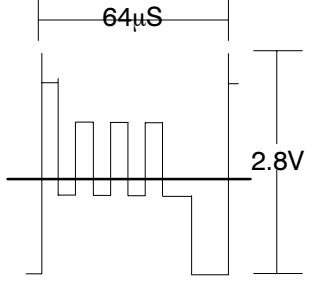
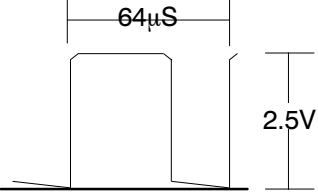
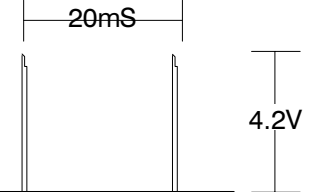
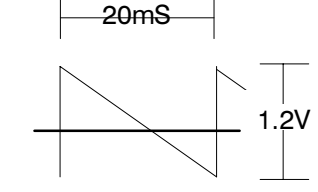
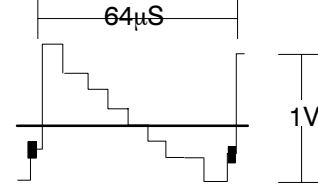
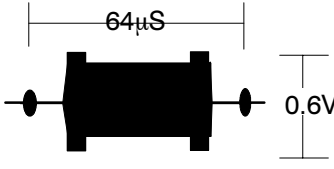
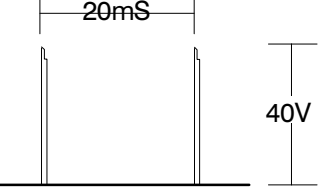
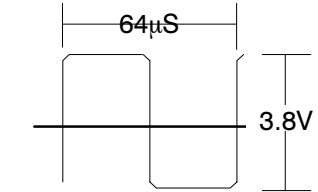
<p>RED DRIVE TPY1</p>  <p>64µS 130V</p>	<p>GREEN DRIVE TPY2</p>  <p>64µS 100V</p>	<p>BLUE DRIVE TPY3</p>  <p>64µS 100V</p>
<p>RED OUTPUT IC 603 PIN 24</p>  <p>64µS 2.8V</p>	<p>GREEN OUTPUT IC 603 PIN 22</p>  <p>64µS 2.7V</p>	<p>BLUE OUTPUT IC 603 PIN 20</p>  <p>64µS 2.8V</p>
<p>HORIZONTAL SYNC IC 3501 PIN 4</p>  <p>64µS 2.5V</p>	<p>VERTICAL SYNC IC 3501 PIN 3</p>  <p>20mS 4.2V</p>	<p>VERT OUTPUT IC (INPUT) IC 451 PIN 1</p>  <p>20mS 1.2V</p>
<p>LUMINANCE IN IC601 PIN 26</p>  <p>64µS 1V</p>	<p>CHROMINANCE IN IC601 PIN 25</p>  <p>64µS 0.6V</p>	<p>VERTICAL OUTPUT (DRIVE) IC 451 PIN 9</p>  <p>20mS 40V</p>
<p>HORIZONTAL OUTPUT IC401 PIN 20</p>  <p>64µS 3.8V</p>		

VIDEO AND AUDIO SIGNAL PROCESSING BLOCK DIAGRAM

BILD SIGNAL / TONSIGNAL BLOCKSCHEMA

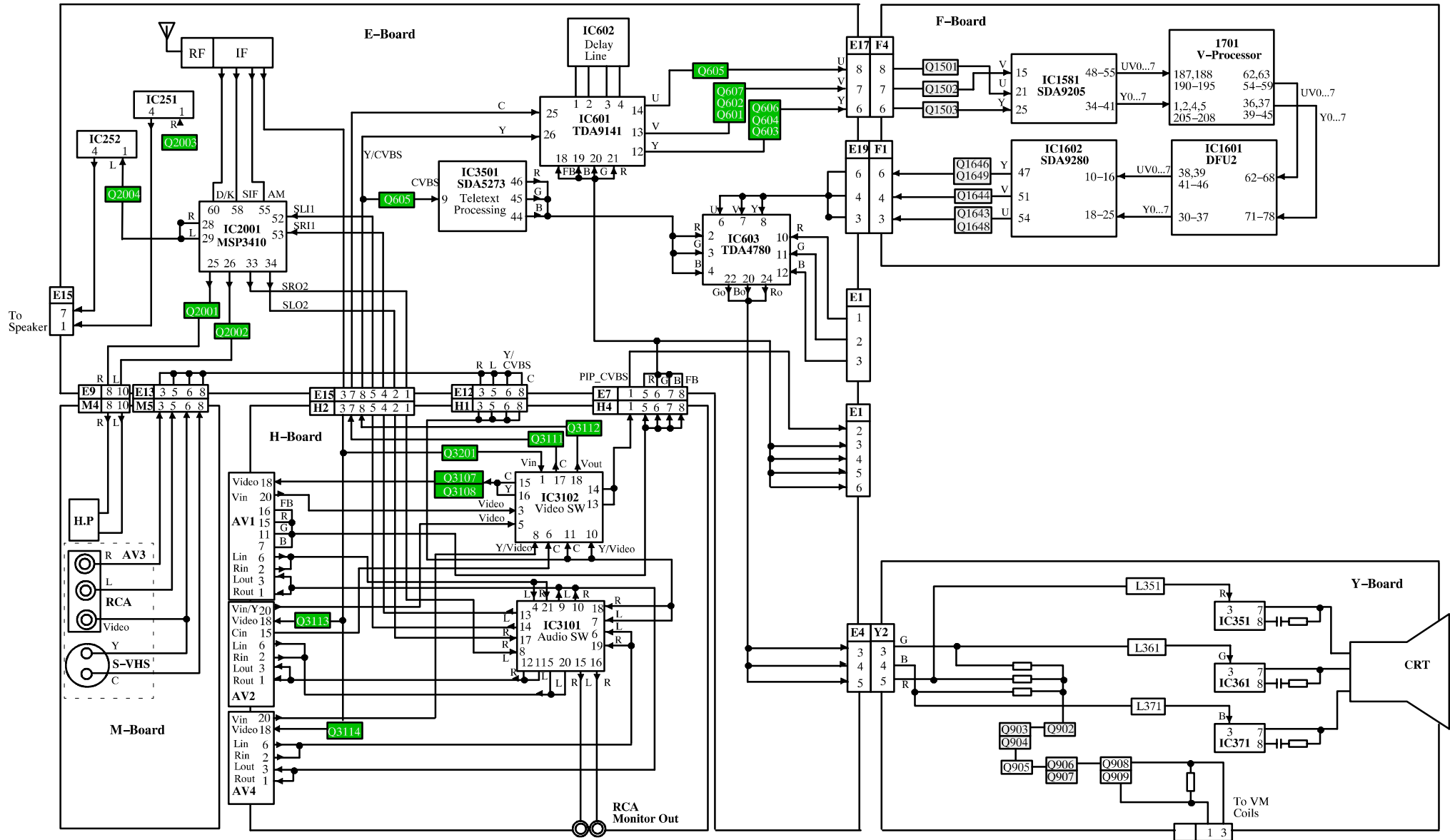

CONTROL BLOCK DIAGRAM STROMVERSORGUNGS BLOCKSCHEMA

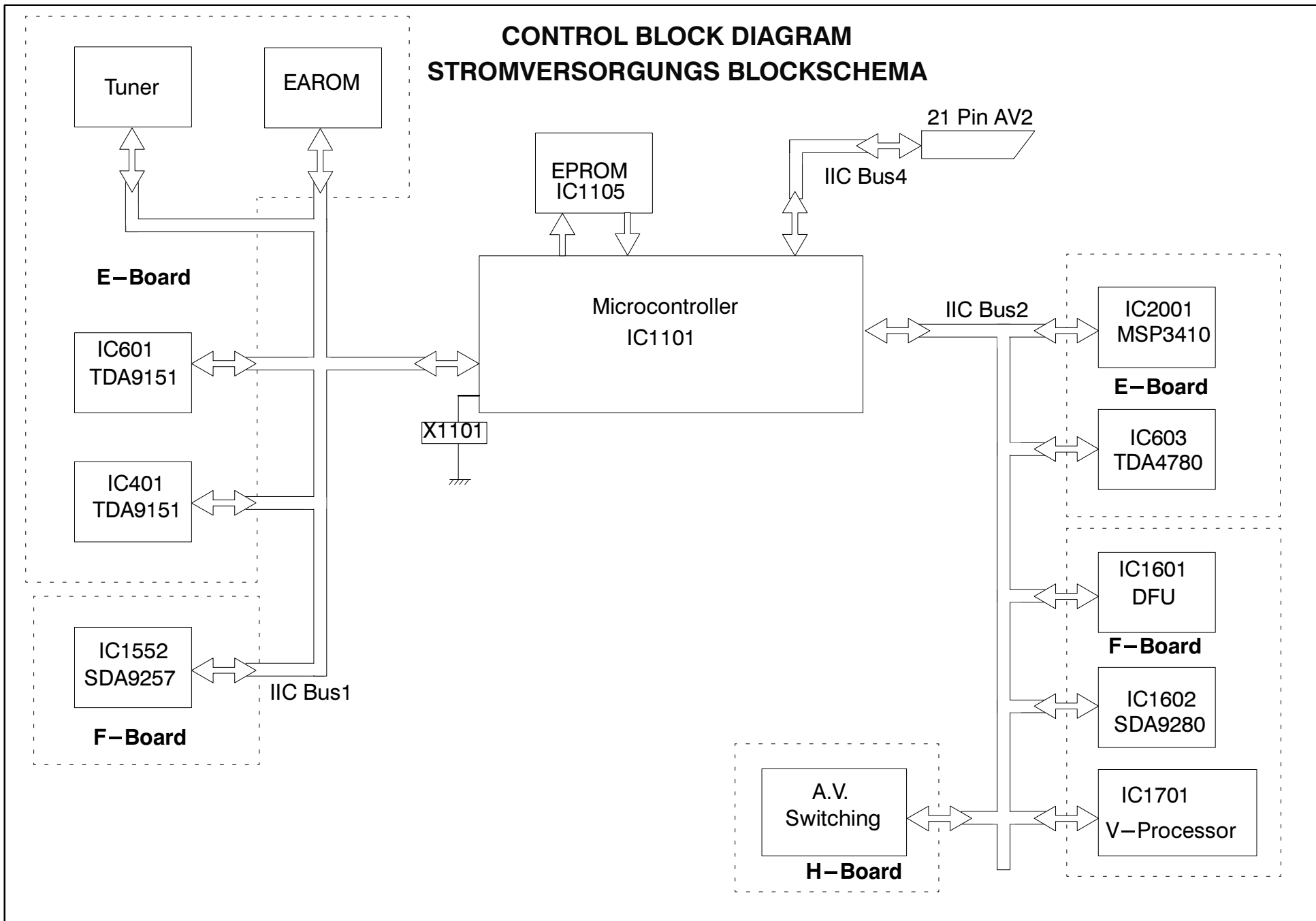

PARTS LOCATION

NOTE :

The numbers on the exploded view below refer to the miscellaneous section of the Replacement Parts List.

EXPLOSIONSZEICHNUNG

Anmerking :

Die Nummer auf den mechanischen Teilen zeigt die Bezugsnummer der Ersatzteilliste an.

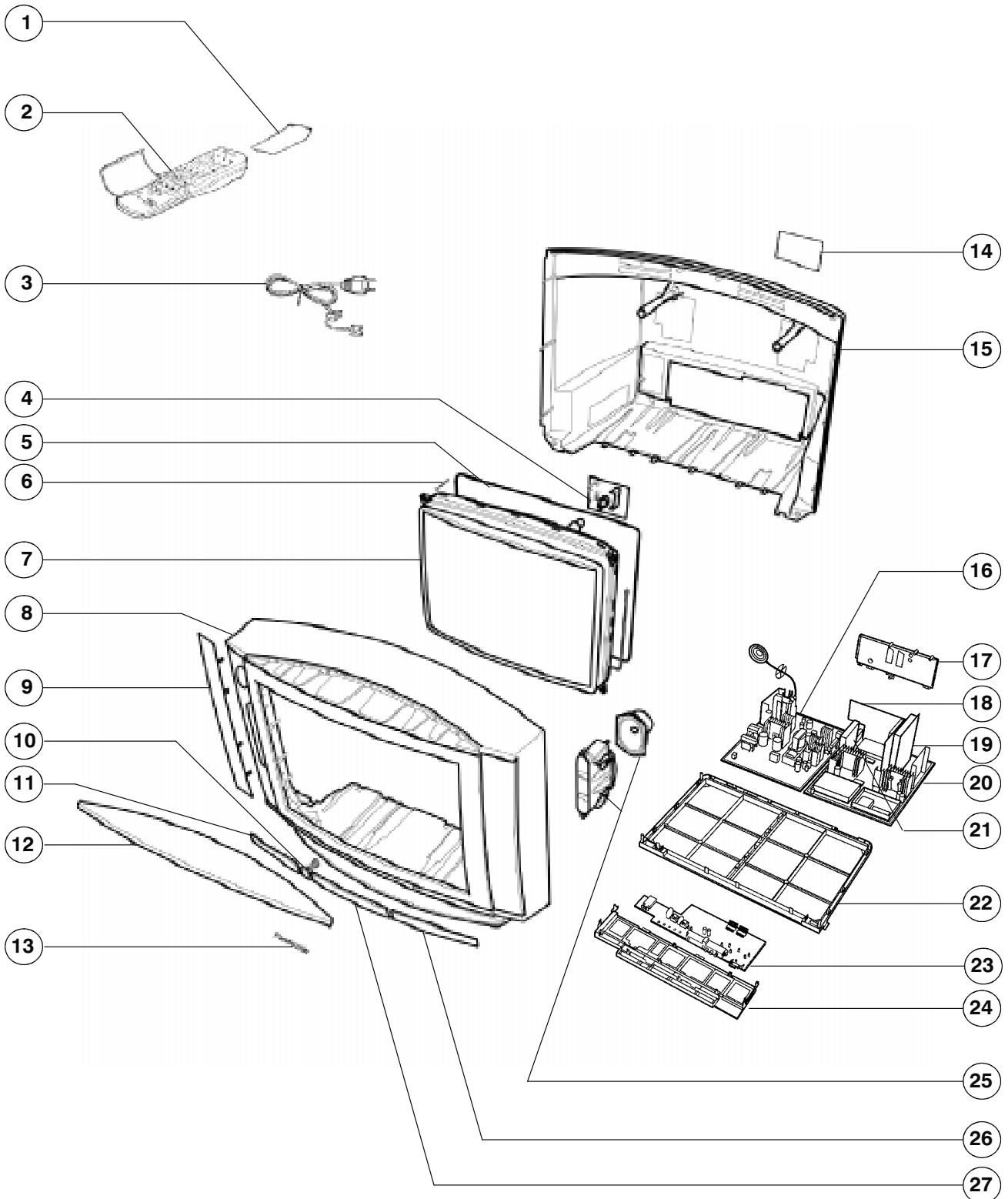

REPLACEMENT PARTS LIST

Important Safety Notice

Components identified by Δ mark have special characteristics important for safety. When replacing any of these components, use only manufacturer's specified parts.

Ref No.	Part No.	Description
MISCELLANEOUS COMPONENTS		
1)	UR51EC780	BATTERY COVER (REMOTE)
2)	EUR51923	REMOTE CONTROL
3)	TSX8E022	POWER CORD Δ
4)	*****	SEE DIFFERENCE LIST
5)	*****	SEE DIFFERENCE LIST
6)	VP17005-32	CRT FIXING SCREW
7)	*****	SEE DIFFERENCE LIST
8)	*****	SEE DIFFERENCE LIST
9)	*****	SEE DIFFERENCE LIST
10)	*****	SEE DIFFERENCE LIST
11)	*****	SEE DIFFERENCE LIST
12)	*****	SEE DIFFERENCE LIST
13)	TBM8E1728	PANASONIC BADGE
14)	*****	SEE DIFFERENCE LIST
15)	*****	SEE DIFFERENCE LIST
16)	*****	SEE DIFFERENCE LIST
17)	TKP8E1166	REAR AV COVER
18)	TNPA0293AB	H P.C.B. Δ
19)	TNPA0756AA	F P.C.B. Δ
20)	*****	SEE DIFFERENCE LIST
21)	TNPA0317AB	B P.C.B. Δ
22)	TMX8E014	CHASSIS FRAME
23)	TNPA0766AA	M P.C.B. Δ
24)	TMW8E025	CONTROL BRACKET
25)	EAG1216A2	SPEAKER
26)	*****	SEE DIFFERENCE LIST
27)	TKP8E1170	DOOR LID (BLACK)
	ERC12GK825	SOLID 0.5W 10% 8M2 Ω
TNR1	ENV57D03G3	TUNER Δ
	PCS-068A-1	68 PIN I.C.SOCKET
	TBM8E1616	PRE-SET LABEL
	TBM8E1675	REAR AV LABEL
	TEK6940	LID CATCHER
	TES8E015	POWER BUTTON SPRING
	TMW8E020-1	LED HOLDER
	TMX8E015	PCB SUPPORT BRACKET
	TQB8E2403A-1	GERMAN INST BOOK Δ
	TQB8E2403B	DUTCH INST BOOK Δ
	TQB8E2403C	ITALIAN INST BOOK Δ
CAPACITORS		
C002	ECUV1H102JCX	S.M.CAP 50V 1nF
C003	ECA1HM101GB	ELECT 50V 100pF
C004	ECUV1H102JCX	S.M.CAP 50V 1nF
C005	ECUV1H102JCX	S.M.CAP 50V 1nF
C006	ECUV1H102JCX	S.M.CAP 50V 1nF
C007	ECUV1H102JCX	S.M.CAP 50V 1nF
C009	ECA1HMR22GB	ELECT 50V 0.22 μ F
C010	ECUV1H102KBX	S.M.CAP 50V 1nF
C014	ECUV1H103ZFX	S.M.CAP 50V 10nF
C015	ECUV1H390JCX	S.M.CAP 50V 39pF
C016	ECUV1H390JCX	S.M.CAP 50V 39pF
C017	ECA1CM470GB	ELECT 16V 47 μ F
C019	ECUV1H561JCX	S.M.CAP 50V 560pF
C020	ECUV1H103ZFX	S.M.CAP 50V 10nF
C022	ECUV1H103ZFX	S.M.CAP 50V 10nF
C023	ECUV1H681JCX	S.M.CAP 50V 680pF
C024	ECUV1H103ZFX	S.M.CAP 50V 10nF
C025	ECUV1H101JCX	S.M.CAP 50V 100pF

Ref No.	Part No.	Description
C026	ECUV1H681JCX	S.M.CAP 50V 680pF
C101	ECUV1H104ZFX	S.M.CAP 50V 100nF
C106	ECUV1H104ZFX	S.M.CAP 50V 100nF
C108	ECUV1H104ZFX	S.M.CAP 50V 100nF
C109	ECUV1H104ZFX	S.M.CAP 50V 100nF
C111	ECUV1H103ZFX	S.M.CAP 50V 10nF
C113	ECUV1H393KBX	S.M.CAP 50V 39nF
C115	ECUV1H104ZFX	S.M.CAP 50V 100nF
C116	ECUV1H030CPX	S.M.CAP 50V 30pF
C117	ECUV1H070DTX	S.M.CAP 50V 70pF
C118	ECEA1CKA100	ELECT 16V 10 μ F
C120	ECEA1HKA2R2	ELECT 50V 2.2 μ F
C121	ECEA1HKA2R2	ELECT 50V 2.2 μ F
C122	ECUV1C105ZFX	S.M.CAP 16V 1000nF
C123	ECEA1HKA2R2	ELECT 50V 2.2 μ F
C124	ECUV1H471JCX	S.M.CAP 50V 470pF
C125	ECUV1H104ZFX	S.M.CAP 50V 100nF
C126	ECUV1H104ZFX	S.M.CAP 50V 100nF
C127	ECEA1CKA100	ELECT 16V 10 μ F
C128	ECUV1H102KBX	S.M.CAP 50V 1nF
C129	ECEA1CKA100	ELECT 16V 10 μ F
C130	ECUV1H104ZFX	S.M.CAP 50V 100nF
C131	ECUV1H102KBX	S.M.CAP 50V 1nF
C132	ECUV1H102KBX	S.M.CAP 50V 1nF
C133	ECUV1H102KBX	S.M.CAP 50V 1nF
C134	ECUV1H104ZFX	S.M.CAP 50V 100nF
C135	ECEA1CKA100	ELECT 16V 10 μ F
C136	ECUV1H104ZFX	S.M.CAP 50V 100nF
C137	ECUV1H100DCX	S.M.CAP 50V 10pF
C138	ECUV1H151JCX	S.M.CAP 50V 150pF
C139	ECUV1H104ZFX	S.M.CAP 50V 100nF
C140	ECUV1H151JCX	S.M.CAP 50V 150pF
C142	ECUV1H100DCX	S.M.CAP 50V 10pF
C143	ECUV1H220JCX	S.M.CAP 50V 22pF
C144	ECUV1H151JCX	S.M.CAP 50V 150pF
C145	ECUV1H151JCX	S.M.CAP 50V 150pF
C146	ECUV1H120JCX	S.M.CAP 50V 12pF
C148	ECUV1H103ZFX	S.M.CAP 50V 10nF
C150	ECEA1CKA100	ELECT 16V 10 μ F
C151	ECUV1H104ZFX	S.M.CAP 50V 100nF
C152	ECUV1H104ZFX	S.M.CAP 50V 100nF
C153	ECUV1H120JCX	S.M.CAP 50V 12pF
C158	ECUV1H103ZFX	S.M.CAP 50V 10nF
C159	ECUV1H080CCX	S.M.CAP 50V 80pF
C251	ECQM1H474J	FILM 50V 470nF
C252	ECUV1H222JCX	S.M.CAP 50V 2.2nF
C254	ECUV1H393KBX	S.M.CAP 50V 39nF
C255	ECEA1CN100	ELECT 16V 10 μ F
C256	ECA1HM330B	ELECT 50V 33pF
C257	ECA1HM100GB	ELECT 50V 10pF
C258	ECQM1H474J	FILM 50V 470nF
C259	ECUV1H222JCX	S.M.CAP 50V 2.2nF
C261	ECUV1H393KBX	S.M.CAP 50V 39nF
C262	ECEA1CN100	ELECT 16V 10 μ F
C263	ECA1HM330B	ELECT 50V 33pF
C264	ECA1HM100GB	ELECT 50V 10pF
C267	ECUV1H103ZFX	S.M.CAP 50V 10nF
C268	ECUV1H223ZFX	S.M.CAP 50V 22nF
C269	ECA1EM222GB	ELECT 25V 2.2nF
C270	ECA1EM222GB	ELECT 25V 2.2nF
C271	ECA1HM010GB	ELECT 50V 1pF
C272	ECA1HM010GB	ELECT 50V 1pF
C273	ECA1HM010GB	ELECT 50V 1pF
C274	ECA1HM010GB	ELECT 50V 1pF

Ref No.	Part No.	Description			
C275	ECUV1C184KBX	S.M.CAP	16V	0.18μF	
C276	ECUV1C184KBX	S.M.CAP	16V	0.18μF	
C277	ECEA1HU471	ELECT	50V	470μF	
C280	ECUV1H562KBX	S.M.CAP	50V	5.6nF	
C281	ECUV1H561JCX	S.M.CAP	50V	560pF	
C282	ECUV1H561JCX	S.M.CAP	50V	560pF	
C283	ECUV1H561JCX	S.M.CAP	50V	560pF	
C352	ECUV1H224ZFX	S.M.CAP	50V	0.22μF	
C353	ECUV1H103KBX	S.M.CAP	50V	10nF	
C354	ECKC2H103J	CERAMIC	50V	10nF	△
C355	ECKC2H102J	CERAMIC	500V	1nF	△
C362	ECUV1H224ZFX	S.M.CAP	50V	0.22μF	
C363	ECUV1H103KBX	S.M.CAP	50V	10nF	
C364	ECKC2H103J	CERAMIC	50V	10nF	△
C365	ECKC2H102J	CERAMIC	500V	1nF	△
C372	ECUV1H224ZFX	S.M.CAP	50V	0.22μF	
C373	ECUV1H103KBX	S.M.CAP	50V	10nF	
C374	ECKC2H103J	CERAMIC	50V	10nF	△
C375	ECKC2H102J	CERAMIC	500V	1nF	△
C381	ECA1HM101GB	ELECT	50V	100pF	
C382	ECA1CM471GB	ELECT	16V	470pF	
C383	ECUV1H103KBX	S.M.CAP	50V	10nF	
C384	ECQM2104KZ	FILM	250V	100nF	
C385	ECEA2EU220	ELECT	250V	22μF	
C386	ECKC3D152J	CERAMIC	2KV	1.5nF	△
C395	ECQM1H104J	FILM	50V	100nF	
C402	ECUV1H104ZFX	S.M.CAP	50V	100nF	
C403	ECA1AM332E	ELECT	10V	3.3nF	
C404	ECUV1H104ZFX	S.M.CAP	50V	100nF	
C405	ECUV1H104ZFX	S.M.CAP	50V	100nF	
C406	ECUV1H471JCX	S.M.CAP	50V	470pF	
C409	ECUV1H101JCX	S.M.CAP	50V	100pF	
C413	ECUV1H561KBX	S.M.CAP	50V	560pF	
C451	ECUV1H104ZFX	S.M.CAP	50V	100nF	
C452	ECA1EM332E	ELECT	25V	3.3nF	
C453	ECEA1HU101	ELECT	50V	100μF	
C455	ECA1HEN100B	ELECT	50V	10pF	
C456	ECQV1104JZ3	FILM	100V	0.1μF	
C457	ECUV1H102JCX	S.M.CAP	50V	1nF	
C462	ECKC3A471J	CERAMIC	1KV	470pF	△
C463	ECUV1H102KBX	S.M.CAP	50V	1nF	
C464	ECKC1H102J	CERAMIC	50V	1000pF	
C501	ECQM1H224J	FILM	50V	220nF	
C502	ECQM2683JZ	FILM	250V	68nF	
C503	ECKC2H102J	CERAMIC	500V	1nF	△
C504	ECQB1H223K	FILM	50V	22nF	
C506	ECKC2H102J	CERAMIC	500V	1nF	△
C552	ECWH15H392J	FILM	3500V	3.9nF	
C553	ECQP1104JZW	FILM	100V	0.10μF	
C555	ECWH15H472J	FILM	1500V	4700μF	
C556	ECEA2CNR47SB	ELECT	160V	R47μF	
C557	ECKC2H331J	CERAMIC	500V	330pF	△
C558	ECA2EM330B	ELECT	250V	33pF	
C559	ECKC2H101J	CERAMIC	500V	100pF	△
C560	ECA1EM332E	ELECT	25V	3.3nF	
C561	ECKC2H561J	CERAMIC	500V	560pF	△
C562	ECA1JM330B	ELECT	63V	33pF	
C563	ECWF2564JBK	FILM	200V	0.56μF	
C564	ECKC1H472J	CERAMIC	50V	4.7nF	
C565	ECQP1823JZW	FILM	100V	82nF	
C571	ECQV1H105JZ	FILM	50V	1μF	
C572	ECWH15H472J	FILM	1500V	4700μF	
C573	ECQF4153JZH	FILM	400V	15nF	
C574	ECWF4684JBB	FILM	400V	0.68μF	
C575	ECWF4684JBB	FILM	400V	0.68μF	
C581	ECQF4123JZH	FILM	400V	12nF	
C584	ECKC3D391J	CERAMIC	2KV	390pF	△
C585	ECKC3A471J	CERAMIC	1KV	470pF	△
C586	ECKC1H103JB	CERAMIC	50V	10nF	
C588	ECKC1H471J	CERAMIC	50V	470pF	
C601	ECUV1H104ZFX	S.M.CAP	50V	100nF	
C602	ECUV1H104ZFX	S.M.CAP	50V	100nF	

Ref No.	Part No.	Description			
C603	ECUV1H104ZFX	S.M.CAP	50V	100nF	
C604	ECUV1H104ZFX	S.M.CAP	50V	100nF	
C605	ECUV1H104ZFX	S.M.CAP	50V	100nF	
C606	ECUV1H104ZFX	S.M.CAP	50V	100nF	
C608	ECUV1H104ZFX	S.M.CAP	50V	100nF	
C609	ECUV1H180JCX	S.M.CAP	50V	18pF	
C610	ECUV1H150JCX	S.M.CAP	50V	15pF	
C611	ECUV1H104ZFX	S.M.CAP	50V	100nF	
C612	ECUV1H332ZFX	S.M.CAP	50V	3.3nF	
C613	ECUV1C474ZFX	S.M.CAP	16V	0.47μF	
C614	ECUV1H332ZFX	S.M.CAP	50V	3.3nF	
C615	ECUV1H104ZFX	S.M.CAP	50V	100nF	
C616	ECUV1H104ZFX	S.M.CAP	50V	100nF	
C617	ECA1CM220GB	ELECT	16V	22μF	
C618	ECUV1H104ZFX	S.M.CAP	50V	100nF	
C619	ECUV1H104ZFX	S.M.CAP	50V	100nF	
C620	ECUV1H104ZFX	S.M.CAP	50V	100nF	
C621	ECUV1H104ZFX	S.M.CAP	50V	100nF	
C622	ECUV1H104ZFX	S.M.CAP	50V	100nF	
C623	ECUV1H103ZFX	S.M.CAP	50V	10nF	
C624	ECUV1H103ZFX	S.M.CAP	50V	10nF	
C625	ECUV1H103ZFX	S.M.CAP	50V	10nF	
C626	ECUV1H103ZFX	S.M.CAP	50V	10nF	
C627	ECUV1H103ZFX	S.M.CAP	50V	10nF	
C628	ECUV1H103ZFX	S.M.CAP	50V	10nF	
C629	ECUV1H103ZFX	S.M.CAP	50V	10nF	
C630	ECUV1H103ZFX	S.M.CAP	50V	10nF	
C631	ECUV1H103ZFX	S.M.CAP	50V	10nF	
C632	ECUV1H103ZFX	S.M.CAP	50V	10nF	
C633	ECUV1H470JCX	S.M.CAP	50V	47pF	
C634	ECA1CM221GB	ELECT	16V	220pF	
C635	ECA1HM220GB	ELECT	50V	22pF	
C636	ECA1HM010GB	ELECT	50V	1pF	
C637	ECQM1H224J	FILM	50V	220nF	
C638	ECA1HM010GB	ELECT	50V	1pF	
C639	ECQM1H224J	FILM	50V	220nF	
C640	ECQM1H224J	FILM	50V	220nF	
C641	ECQM1H224J	FILM	50V	220nF	
C642	ECA1AM470GB	ELECT	10V	47pF	
C643	ECUV1H104ZFX	S.M.CAP	50V	100nF	
C644	ECA1CM470GB	ELECT	16V	47μF	
C645	ECUV1H104ZFX	S.M.CAP	50V	100nF	
C646	ECUV1H104ZFX	S.M.CAP	50V	100nF	
C647	ECEA1CN470	ELECT	16V	47μF	
C648	ECEA1CN470	ELECT	16V	47μF	
C651	ECUV1H820JCX	S.M.CAP	50V	82pF	
C654	ECUV1H393KBX	S.M.CAP	50V	39nF	
C655	ECUV1E563KBX	S.M.CAP	25V	56nF	
C657	ECUV1C474ZFX	S.M.CAP	16V	0.47μF	
C659	ECUV1H821KBX	S.M.CAP	50V	820pF	
C661	ECUV1H103ZFX	S.M.CAP	50V	10nF	
C662	ECUV1H470JCX	S.M.CAP	50V	47pF	
C663	ECUV1H150JCX	S.M.CAP	50V	15pF	
C664	ECUV1H103ZFX	S.M.CAP	50V	10nF	
C703	ECUV1C224KBX	S.M.CAP	16V	220nF	
C752	ECKC2H103J	CERAMIC	50V	10nF	△
C803	ECQE2A474MWB	FILM	100V	0.47μF	
C804	ECQU2A154MN	FILM	250V	150nF	
C806	ECQE6104K	FILM	600V	100nF	△
C807	ECQB1H473K	FILM	50V	47nF	
C808	ECQB1H333J	FILM	50V	33nF	
C810	222233510154	CAPACITOR		0.15μF	
C811	ECQB1H104J	FILM	50V	100nF	
C812	ECQB1H562K	FILM	50V	5.6nF	
C813	ECKC2H472J	CERAMIC	500V	4.7nF	△
C814	ECKC2H472J	CERAMIC	500V	4.7nF	△
C815	ECA1CM331B	ELECT	16V	330pF	
C816	ECQB1H122J	FILM	50V	1.2nF	
C817	ECKC2H472J	CERAMIC	500V	4.7nF	△
C818	ECKC2H472J	CERAMIC	500V	4.7nF	△
C819	ECOS2GG181NG	ELECT	400V	180μF	△
C820	ECOS2GG181NG	ELECT	400V	180μF	△

Ref No.	Part No.	Description			
C821	ECQB1H222J	FILM	50V	2200pF	
C822	ECKC3D471JB	CERAMIC	2KV	470pF	△
C824	ECQB1H121KF3	FILM	50V	120pF	
C826	ECQB1H473K	FILM	50V	47nF	
C827	ECKCNS332J	CERAMIC	1.2KV	3.3nF	△
C830	ECQE4105JFW	FILM	400V	1.0μF	
C831	ECKC3D471JB	CERAMIC	2KV	470pF	△
C833	ECQB1H682K	FILM	50V	6.8nF	
C835	ECQB1H332K	FILM	50V	3.3nF	
C848	ECKC2H471J	CERAMIC	500V	470pF	△
C849	ECKC2H471J	CERAMIC	500V	470pF	△
C851	ECQM1H104J	FILM	50V	100nF	
C852	ECKC3D222JB	CERAMIC	2KV	2200pF	△
C853	ECA1CM471GB	ELECT	16V	470pF	
C854	ECA1EM471GB	ELECT	25V	470pF	
C855	ECEA1HU102	ELECT	50V	1000μF	
C856	ECEA1HU471	ELECT	50V	470μF	
C857	ECA1EM471GB	ELECT	25V	470pF	
C858	ECOS2EA271BB	ELECT	250V	270pF	
C859	ECKC2H471J	CERAMIC	500V	470pF	△
C861	ECOS2EA221AB	ELECT	250V	220μF	
C863	ECA1EM222GB	ELECT	25V	2.2nF	
C864	ECA0JM102GB	ELECT	6.3V	1nF	
C866	ECA1HM101GB	ELECT	25V	100pF	
C867	ECA1CM222GB	ELECT	16V	2200μF	
C868	ECA1CM100GB	ELECT	16V	10pF	
C871	ECA0JM102GB	ELECT	6.3V	1nF	
C872	ECA1CM222GB	ELECT	16V	2200μF	
C874	ECKC1H102J	CERAMIC	50V	1000pF	
C901	ECUV1H030CCX	S.M.CAP	50V	30pF	
C902	ECA1VM101GB	ELECT	35V	100pF	
C903	ECKC1H103JB	CERAMIC	50V	10nF	
C904	ECUV1H103ZFX	S.M.CAP	50V	10nF	
C905	ECA1CM100GB	ELECT	16V	10pF	
C906	ECUV1H102KBX	S.M.CAP	50V	1nF	
C908	ECUV1H151JCX	S.M.CAP	50V	150pF	
C909	ECKC2H472J	CERAMIC	500V	4.7nF	△
C910	ECKC2H472J	CERAMIC	500V	4.7nF	△
C911	ECUV1H151JCX	S.M.CAP	50V	150pF	
C912	ECEA2EU220	ELECT	250V	22μF	
C913	ECA1HM101GB	ELECT	50V	100pF	
C914	ECA1HM101GB	ELECT	50V	100pF	
C915	ECA1CM471GB	ELECT	16V	470pF	
C916	ECEA2EU220	ELECT	250V	22μF	
C917	ECA1HM100GB	ELECT	50V	10pF	
C918	ECUV1H103ZFX	S.M.CAP	50V	10nF	
C919	ECCR2H680J	CERAMIC	500V	68pF	
C1051	ECKC1H101J	CERAMIC	50V	100pF	
C1052	ECA1VM470B	ELECT	35V	47pF	
C1053	ECKC1H103JB	CERAMIC	50V	10nF	
C1102	ECUV1H104ZFX	S.M.CAP	50V	100nF	
C1103	ECUV1H104ZFX	S.M.CAP	50V	100nF	
C1104	ECA0JM101G	ELECT	6.3V	100pF	
C1105	ECUV1H330JCX	S.M.CAP	50V	33pF	
C1106	ECUV1H330JCX	S.M.CAP	50V	33pF	
C1107	ECUV1H391JCX	S.M.CAP	50V	390pF	
C1108	ECUV1H103ZFX	S.M.CAP	50V	10nF	
C1109	ECUV1H472KBX	S.M.CAP	50V	4.7nF	
C1110	ECUV1H104ZFX	S.M.CAP	50V	100nF	
C1111	ECUV1H101JCX	S.M.CAP	50V	100pF	
C1112	ECUV1H103ZFX	S.M.CAP	50V	10nF	
C1114	ECUV1H102JCX	S.M.CAP	50V	1nF	
C1115	ECUV1H102JCX	S.M.CAP	50V	1nF	
C1126	ECUV1H104ZFX	S.M.CAP	50V	100nF	
C1127	ECUV1H104ZFX	S.M.CAP	50V	100nF	
C1129	ECA1AM470GB	ELECT	10V	47pF	
C1130	ECUV1H104ZFX	S.M.CAP	50V	100nF	
C1131	ECUV1H101JCX	S.M.CAP	50V	100pF	
C1133	ECUV1C184KBX	S.M.CAP	16V	0.18μF	
C1134	ECUV1H103KBX	S.M.CAP	50V	10nF	
C1135	ECUV1H103ZFX	S.M.CAP	50V	10nF	
C1136	ECUV1H101JCX	S.M.CAP	50V	100pF	
C1137	ECUV1H102KBX	S.M.CAP	50V	1nF	

Ref No.	Part No.	Description			
C1138	ECUV1H104ZFX	S.M.CAP	50V	100nF	
C1304	ECUV1H103ZFX	S.M.CAP	50V	10nF	
C1305	ECA1HM101GB	ELECT	50V	100pF	
C1317	ECUV1H104ZFX	S.M.CAP	50V	100nF	
C1321	ECUV1H104ZFX	S.M.CAP	50V	100nF	
C1322	ECUV1H101JCX	S.M.CAP	50V	100pF	
C1327	ECUV1H104ZFX	S.M.CAP	50V	100nF	
C1508	ECUV1H103KBX	S.M.CAP	50V	10nF	
C1509	ECA1VM470B	ELECT	35V	47pF	
C1518	ECA1HM101GB	ELECT	50V	100pF	
C1519	ECA1HM101GB	ELECT	50V	100pF	
C1520	ECA1HM101GB	ELECT	50V	100pF	
C1524	ERJ6GEY0R00	S.M.CARB	0.1W	5%	Ω
C1525	ECUV1H221JCX	S.M.CAP	50V	220pF	
C1529	ERJ6GEY0R00	S.M.CARB	0.1W	5%	Ω
C1531	ECUV1H221JCX	S.M.CAP	50V	220pF	
C1532	ECUV1H680JCX	S.M.CAP	50V	68pF	
C1533	ECUV1H560JCX	S.M.CAP	50V	56pF	
C1534	ECUV1H271JCX	S.M.CAP	50V	270pF	
C1537	ECA0JM102GB	ELECT	6.3V	1nF	
C1538	ECUV1H151JCX	S.M.CAP	50V	150pF	
C1539	ECUV1H152JCX	S.M.CAP	50V	1.5pF	
C1540	ECUV1H151JCX	S.M.CAP	50V	150pF	
C1541	ECUV1H152JCX	S.M.CAP	50V	1.5pF	
C1542	ECUV1H101JCX	S.M.CAP	50V	100pF	
C1543	ECUV1H391JCX	S.M.CAP	50V	390pF	
C1552	ECUV1H104ZFX	S.M.CAP	50V	100nF	
C1553	ECUV1H270JCX	S.M.CAP	50V	27pF	
C1554	ECUV1H104ZFX	S.M.CAP	50V	100nF	
C1555	ECA0JM331GB	ELECT	6.3V	330pF	
C1556	ECUV1H270JCX	S.M.CAP	50V	27pF	
C1557	ECUV1H270JCX	S.M.CAP	50V	27pF	
C1558	ECUV1H104ZFX	S.M.CAP	50V	100nF	
C1559	ECUV1H103KBX	S.M.CAP	50V	10nF	
C1560	ECUV1H103KBX	S.M.CAP	50V	10nF	
C1561	ECUV1H104ZFX	S.M.CAP	50V	100nF	
C1562	ECA0JM331GB	ELECT	6.3V	330pF	
C1564	ECUV1H104ZFX	S.M.CAP	50V	100nF	
C1575	ECUV1H104ZFX	S.M.CAP	50V	100nF	
C1576	ECUV1H104ZFX	S.M.CAP	50V	100nF	
C1577	ECA1HM101GB	ELECT	50V	100pF	
C1579	ECUV1H104ZFX	S.M.CAP	50V	100nF	
C1580	ECUV1H104ZFX	S.M.CAP	50V	100nF	
C1583	ECUV1H104ZFX	S.M.CAP	50V	100nF	
C1584	ECUV1H104ZFX	S.M.CAP	50V	100nF	
C1585	ECUV1H104ZFX	S.M.CAP	50V	100nF	
C1586	ECUV1H104ZFX	S.M.CAP	50V	100nF	
C1588	ECA1VM470B	ELECT	35V	47pF	
C1590	ECUV1H104ZFX	S.M.CAP	50V	100nF	
C1591	ECUV1H104ZFX	S.M.CAP	50V	100nF	
C1592	ECUV1H104ZFX	S.M.CAP	50V	100nF	
C1593	ECA1HM101GB	ELECT	50V	100pF	
C1594	ECUV1H104ZFX	S.M.CAP	50V	100nF	
C1595	ECUV1H104ZFX	S.M.CAP	50V	100nF	
C1596	ECUV1H104ZFX	S.M.CAP	50V	100nF	
C1599	ECA1HM101GB	ELECT	50V	100pF	
C1601	ECUV1H104ZFX	S.M.CAP	50V	100nF	
C1602	ECUV1H104ZFX	S.M.CAP	50V	100nF	
C1603	ECUV1H103KBX	S.M.CAP	50V	10nF	
C1604	ECUV1H104ZFX	S.M.CAP	50V	100nF	
C1605	ECUV1H104ZFX	S.M.CAP	50V	100nF	
C1606	ECUV1H104ZFX	S.M.CAP	50V	100nF	
C1607	ECUV1H104ZFX	S.M.CAP	50V	100nF	
C1608	ECA1HM101GB	ELECT	50V	100pF	
C1610	ECUV1H104ZFX	S.M.CAP	50V	100nF	
C1611	ECUV1H103KBX	S.M.CAP	50V	10nF	
C1612	ECUV1H104ZFX	S.M.CAP	50V	100nF	
C1613	ECUV1H104ZFX	S.M.CAP	50V	100nF	
C1614	ECUV1H104ZFX	S.M.CAP	50V	100nF	
C1616	ECUV1H152JCX	S.M.CAP	50V	1.5pF	
C1617	ECUV1H104ZFX	S.M.CAP	50V	100nF	
C1618	ECUV1H104ZFX	S.M.CAP	50V	100nF	
C1619	ECUV1H104ZFX	S.M.CAP	50V	100nF	

Ref No.	Part No.	Description		
C1620	ECUV1H104ZFX	S.M.CAP	50V	100nF
C1621	ECA1HM101GB	ELECT	50V	100pF
C1622	ECUV1H104ZFX	S.M.CAP	50V	100nF
C1625	ECEA1CN470	ELECT	16V	47µF
C1626	ECUV1H100DCX	S.M.CAP	50V	10pF
C1627	ECUV1H330JCX	S.M.CAP	50V	33pF
C1628	ECUV1H271JCX	S.M.CAP	50V	270pF
C1629	ECUV1H100DCX	S.M.CAP	50V	10pF
C1630	ECUV1H330JCX	S.M.CAP	50V	33pF
C1631	ECUV1H271JCX	S.M.CAP	50V	270pF
C1632	ECUV1H020CCX	S.M.CAP	50V	2pF
C1633	ECUV1H050DCX	S.M.CAP	50V	5pF
C1634	ECUV1H470JCX	S.M.CAP	50V	47pF
C1641	ECA1VM470B	ELECT	35V	47pF
C1642	ECUV1H104ZFX	S.M.CAP	50V	100nF
C1671	ECUV1H330JCX	S.M.CAP	50V	33pF
C1701	ECUV1H104ZFX	S.M.CAP	50V	100nF
C1702	ECUV1H104ZFX	S.M.CAP	50V	100nF
C1703	ECUV1H103ZFX	S.M.CAP	50V	10nF
C1704	ECUV1H104ZFX	S.M.CAP	50V	100nF
C1705	ECA1HM101GB	ELECT	50V	100pF
C1706	ECUV1H104ZFX	S.M.CAP	50V	100nF
C2001	ECA1CM100GB	ELECT	16V	10pF
C2002	ECUV1H104ZFX	S.M.CAP	50V	100nF
C2003	ECUV1H104ZFX	S.M.CAP	50V	100nF
C2004	ECUV1H102JCX	S.M.CAP	50V	1nF
C2005	ECUV1H391JCX	S.M.CAP	50V	390pF
C2006	ECUV1H391JCX	S.M.CAP	50V	390pF
C2007	ECUV1H102JCX	S.M.CAP	50V	1nF
C2008	ECUV1H102JCX	S.M.CAP	50V	1nF
C2009	ECUV1H102JCX	S.M.CAP	50V	1nF
C2010	ECUV1H102JCX	S.M.CAP	50V	1nF
C2011	ECUV1H102JCX	S.M.CAP	50V	1nF
C2012	ECUV1H102JCX	S.M.CAP	50V	1nF
C2014	ECQM1H334J	FILM	50V	330nF
C2017	ECA1CM100GB	ELECT	16V	10pF
C2018	ECA1CM100GB	ELECT	16V	10pF
C2019	ECA1HM101GB	ELECT	50V	100pF
C2020	ECUV1H104ZFX	S.M.CAP	50V	100nF
C2021	ECUV1H104ZFX	S.M.CAP	50V	100nF
C2022	ECA1HM3R3GB	ELECT	50V	3.3µF
C2023	ECUV1H471JCX	S.M.CAP	50V	470pF
C2024	ECUV1H471JCX	S.M.CAP	50V	470pF
C2025	ECUV1H221JCX	S.M.CAP	50V	220pF
C2026	ECUV1H221JCX	S.M.CAP	50V	220pF
C2027	ECUV1H221JCX	S.M.CAP	50V	220pF
C2028	ECUV1H221JCX	S.M.CAP	50V	220pF
C2029	ECUV1H221JCX	S.M.CAP	50V	220pF
C2030	ECUV1H221JCX	S.M.CAP	50V	220pF
C2031	ECUV1H104ZFX	S.M.CAP	50V	100nF
C2032	ECA1CM100GB	ELECT	16V	10pF
C2034	ECUV1H070DCX	S.M.CAP	50V	7pF
C2035	ECUV1H560JCX	S.M.CAP	50V	56pF
C2036	ECUV1H100DCX	S.M.CAP	50V	10pF
C2037	ECUV1H220JCX	S.M.CAP	50V	22pF
C2039	ECUV1H070DCX	S.M.CAP	50V	7pF
C2040	ECUV1H560JCX	S.M.CAP	50V	56pF
C2041	ECUV1H560JCX	S.M.CAP	50V	56pF
C2042	ECUV1H104ZFX	S.M.CAP	50V	100nF
C2043	ECA1CM100GB	ELECT	16V	10pF
C2044	ECUV1H010CCX	S.M.CAP	50V	1pF
C2045	ECUV1H010CCX	S.M.CAP	50V	1pF
C2050	ECUV1H223ZFX	S.M.CAP	50V	22nF
C2051	ECUV1H223ZFX	S.M.CAP	50V	22nF
C2052	ECUV1H103ZFX	S.M.CAP	50V	10nF
C2053	ECUV1H103ZFX	S.M.CAP	50V	10nF
C2054	ECA1CM331B	ELECT	16V	330pF
C2055	ECA1CM331B	ELECT	16V	330pF
C2058	ECUV1H683ZFX	S.M.CAP	50V	68nF
C2059	ECUV1H102KBX	S.M.CAP	50V	1nF
C2060	ECUV1H102KBX	S.M.CAP	50V	1nF
C2351	ECA1CM471GB	ELECT	16V	470pF
C2352	ECA1CM471GB	ELECT	16V	470pF

Ref No.	Part No.	Description			
C2353	ECA1HM4R7GB	ELECT	50V	4.7µF	
C2354	ECKC1H103JB	CERAMIC	50V	10nF	
C2355	ECA1HMR33GB	ELECT	50V	0.33µF	
C2356	ECKC1H103JB	CERAMIC	50V	10nF	
C2360	ECKC1H103JB	CERAMIC	50V	10nF	
C2361	ECA1CM471GB	ELECT	16V	470pF	
C2362	ECA1CM471GB	ELECT	16V	470pF	
C2363	ECA1HM4R7GB	ELECT	50V	4.7µF	
C2364	ECKC1H103JB	CERAMIC	50V	10nF	
C2365	ECA1HMR33GB	ELECT	50V	0.33µF	
C2366	ECKC1H103JB	CERAMIC	50V	10nF	
C3001	ECKC1H561J	CERAMIC	50V	560pF	
C3002	ECKC1H561J	CERAMIC	50V	560pF	
C3005	ECKC1H151J	CERAMIC	50V	150pF	
C3101	ECEA1HN4R7UB	ELECT	50V	4.7µF	
C3102	ECA1HM470GB	ELECT	50V	47µF	
C3103	ECA1CM470GB	ELECT	16V	47µF	
C3107	ECA1HM470GB	ELECT	50V	47µF	
C3108	ECA1CM470GB	ELECT	16V	47µF	
C3111	ECUV1H102JCX	S.M.CAP	50V	1nF	
C3113	ECA1HM470GB	ELECT	50V	47µF	
C3114	ECA1CM470GB	ELECT	16V	47µF	
C3115	ECEA1HNR47UB	ELECT	50V	0.47µF	
C3117	ECEA1HN4R7UB	ELECT	50V	4.7µF	
C3119	ECA1HM470GB	ELECT	50V	47µF	
C3120	ECA1CM470GB	ELECT	16V	47µF	
C3123	ECEA1HN4R7UB	ELECT	50V	4.7µF	
C3126	ECEA1HN4R7UB	ELECT	50V	4.7µF	
C3128	ECEA1HN4R7UB	ELECT	50V	4.7µF	
C3130	ECEA1HN4R7UB	ELECT	50V	4.7µF	
C3131	ECUV1H473KBX	S.M.CAP	50V	47nF	
C3132	ECA1CM470GB	ELECT	16V	47µF	
C3133	ECA1CM470GB	ELECT	16V	47µF	
C3134	ECA1CM470GB	ELECT	16V	47µF	
C3136	ECA1CM470GB	ELECT	16V	47µF	
C3137	ECA1HM470GB	ELECT	50V	47µF	
C3138	ECA1HM470GB	ELECT	50V	47µF	
C3139	ECUV1H222JCX	S.M.CAP	50V	2.2nF	
C3140	ECUV1H222JCX	S.M.CAP	50V	2.2nF	
C3143	ECUV1H561JCX	S.M.CAP	50V	560pF	
C3146	ECUV1H561JCX	S.M.CAP	50V	560pF	
C3148	ECA1HM4R7GB	ELECT	50V	4.7µF	
C3149	ECUV1H561JCX	S.M.CAP	50V	560pF	
C3150	ECA1HM4R7GB	ELECT	50V	4.7µF	
C3151	ECUV1H561JCX	S.M.CAP	50V	560pF	
C3154	ECUV1H104ZFX	S.M.CAP	50V	100nF	
C3156	ECA1CM470GB	ELECT	16V	47µF	
C3158	ECUV1H102JCX	S.M.CAP	50V	1nF	
C3160	ECUV1H104ZFX	S.M.CAP	50V	100nF	
C3162	ECA1CM471GB	ELECT	16V	470pF	
C3163	ECA1HMR47GB	ELECT	50V	0.47µF	
C3165	ECA1HM470GB	ELECT	50V	47µF	
C3169	ECUV1H102JCX	S.M.CAP	50V	1nF	
C3170	ECUV1H561JCX	S.M.CAP	50V	560pF	
C3172	ECUV1H561JCX	S.M.CAP	50V	560pF	
C3173	ECA1HMR47GB	ELECT	50V	0.47µF	
C3174	ECUV1H561JCX	S.M.CAP	50V	560pF	
C3178	ECUV1H561JCX	S.M.CAP	50V	560pF	
C3180	ECA1HMR47GB	ELECT	50V	0.47µF	
C3181	ERJ6GEY0R00	S.M.CARB	0.1W	5%	Ω
C3182	ECUV1H102JCX	S.M.CAP	50V	1nF	
C3183	ERJ6GEY0R00	S.M.CARB	0.1W	5%	Ω
C3184	ECUV1H473KBX	S.M.CAP	50V	47nF	
C3185	ERJ6GEY0R00	S.M.CARB	0.1W	5%	Ω
C3186	ECEA1HNR47UB	ELECT	50V	0.47µF	
C3187	ECA1HM470GB	ELECT	50V	47µF	
C3188	ECEA1CN470	ELECT	16V	47µF	
C3190	ECA1HMR47GB	ELECT	50V	0.47µF	
C3191	ECA1HM470GB	ELECT	50V	47µF	
C3192	ECUV1H473KBX	S.M.CAP	50V	47nF	
C3201	ECA1HM010GB	ELECT	50V	1pF	
C3202	ECUV1H473ZFX	S.M.CAP	50V	47nF	
C3203	ECA1CM100GB	ELECT	16V	10pF	

Ref No.	Part No.	Description
C3204	ECUV1H473ZFX	S.M.CAP 50V 47nF
C3351	ECA1HM101GB	ELECT 50V 100pF
C3501	ECUV1H220JCX	S.M.CAP 50V 22pF
C3502	ECUV1H220JCX	S.M.CAP 50V 22pF
C3503	ECEA1HKN010	ELECT 50V 1µF
C3504	ECUV1H224ZFX	S.M.CAP 50V 0.22µF
C3510	ECUV1H103ZFX	S.M.CAP 50V 10nF
C3511	ECA1HM101GB	ELECT 50V 100pF
C3512	ECUV1H104ZFX	S.M.CAP 50V 100nF
C3514	ECUV1H104ZFX	S.M.CAP 50V 100nF
C3515	ECA0JM331GB	ELECT 6.3V 330pF
C3516	ECUV1H104ZFX	S.M.CAP 50V 100nF
C3521	ECA1HM101GB	ELECT 50V 100pF
C3522	ECUV1H104ZFX	S.M.CAP 50V 100nF
C3801	ECA1HM010GB	ELECT 50V 1pF
C3802	ECUV1H104ZFX	S.M.CAP 50V 100nF
C3803	ECA1CM471GB	ELECT 16V 470pF
C3807	ECUV1H104ZFX	S.M.CAP 50V 100nF
C3808	ECUV1H104ZFX	S.M.CAP 50V 100nF
C3809	ECA0JM101G	ELECT 6.3V 100pF
C3810	ECUV1H103KBX	S.M.CAP 50V 10nF
C3812	ECA1CM221GB	ELECT 16V 220pF

DIODES

D001	MA4020	DIODE
D002	MA4020	DIODE
D103	BA582	DIODE
D104	BA582	DIODE
D251	MA165TA5	DIODE 1SS133T-77
D252	MA165TA5	DIODE 1SS133T-77
D253	MA165TA5	DIODE 1SS133T-77
D254	MA165TA5	DIODE 1SS133T-77
D351	ERA15-04V3	COIL
D352	ERA15-04V3	COIL
D361	ERA15-04V3	COIL
D362	ERA15-04V3	COIL
D371	ERA15-04V3	COIL
D372	ERA15-04V3	COIL
D387	MA2160LFS	DIODE
D401	MA165TA5	DIODE 1SS133T-77
D451	MA4056	DIODE
D452	MA2330-ALF	DIODE
D453	TVSEM01ZV0	DIODE
D502	1SS254T-77	DIODE
D503	EU02	DIODE
D504	EU02	DIODE
D531	1SS254T-77	DIODE
D532	1SS254T-77	DIODE
D533	1SS254T-77	DIODE
D551	EU02	DIODE
D556	AU02V0	DIODE
D557	ERC91-02L9	DIODE
D558	AU02V0	DIODE
D559	MTZJT-7736A	DIODE
D560	1SS252T-77	DIODE
D561	1SS254T-77	DIODE
D563	RH3GLF102	DIODE
D571	FMV-3GULF027	DIODE
D574	1SS252T-77	DIODE
D575	1SS252T-77	DIODE
D602	MA165TA5	DIODE 1SS133T-77
D603	MA165TA5	DIODE 1SS133T-77
D604	MA4062	DIODE
D706	MA165TA5	DIODE 1SS133T-77
D707	MA188TA	DIODE
D806	TF361MALF3	DIODE
D807	D6SB80LF-B	DIODE
D808	1SS254T-77	DIODE
D809	ERA22-02V3	DIODE
D810	MA2160LFS	DIODE
D812	MTZJT-775.6B	DIODE
D813	MA700TA5	DIODE
D814	AU01ZV0	DIODE

Ref No.	Part No.	Description
D815	PC123FY2	DIODE
D817	D5L60F4015	DIODE
D818	TMPG10G3	DIODE
D819	ERA81004V3	DIODE
D820	MA4100	DIODE
D821	EU02AV0	DIODE
D822	MTZJT-7718C	DIODE
D845	1SS254T-77	DIODE
D846	TVSS1WBS20	DIODE
D847	ERA15-01V1	DIODE
D848	EU02	DIODE
D849	FMGG26S	DIODE
D850	EU02	DIODE
D851	FMGG2CS	DIODE
D852	MTZJT-779.1C	DIODE
D853	1SS254T-77	DIODE
D854	1SS254T-77	DIODE
D855	D10SC6MRL	DIODE
D857	FML22SLF610	DIODE
D860	1SS254T-77	DIODE
D861	MTZJT-7713B	DIODE
D862	MA4104	DIODE
D901	1SS254T-77	DIODE
D902	1SS254T-77	DIODE
D903	1SS254T-77	DIODE
D1051	SLR56UR3FLF	LED
D1052	AU01V0	DIODE
D1053	AU01V0	DIODE
D1054	AU01V0	DIODE
D1055	AU01V0	DIODE
D1056	AU01V0	DIODE
D1057	AU01V0	DIODE
D1102	MA4051	DIODE
D1107	MTZJT-775.6A	DIODE
D1108	1SS254T-77	DIODE
D1109	1SS254T-77	DIODE
D1113	MA4051	DIODE
D1552	MA151ATX	DIODE
D2005	MA723TA5	DIODE
D2006	MA723TA5	DIODE
D3101	PMLL5242B	DIODE
D3102	PMLL5242B	DIODE
D3103	PMLL5242B	DIODE
D3105	PMLL5242B	DIODE
D3107	PMLL5242B	DIODE
D3109	PMLL5242B	DIODE
D3110	PMLL5242B	DIODE
D3111	PMLL5242B	DIODE
D3112	PMLL5242B	DIODE
D3115	PMLL5242B	DIODE
D3117	PMLL5242B	DIODE
D3120	RLS72TE-11	DIODE OR PMLL4148
D3351	1SS254T-77	DIODE
D3501	MA4030	DIODE
D3801	MA4043	DIODE
D3802	MTZJT-778.2A	DIODE
D3803	ERA81004V3	DIODE
D3805	MA4091	DIODE
D3806	MA165TA5	DIODE 1SS133T-77
D3807	MA165TA5	DIODE 1SS133T-77

FUSES

F532	TR5-T1250	FUSE	▲
F801	XBA2C50TH15	FUSE	
F845	TR5-T2000	FUSE	▲
F846	TR5-T1250	FUSE	▲
F8011	EYF52BC	FUSE HOLDER	
F8012	EYF52BC	FUSE HOLDER	

INTEGRATED CIRCUITS

IC101	TDA9814TV3	VIF
IC1051	RPM-637CBRL	LED RECEIVER
IC1101	SDA30C164-2	MICRO PROCESSOR

Ref No.	Part No.	Description
IC1102	S-80745AL-Z	RESET
IC1103	MN1280R	RESET
IC1551	SN74F04DR	CLOCK
IC1552	SDA9257	CLOCK GENERATOR
IC1581	SDA9205-2GEG	A/D CONVERTER
IC1601	UPD93213GF	DFU
IC1602	SDA9280B22GE	VIDEO PROCESSOR
IC1701	SDA9255GEG	VIDEO PROCESSOR
IC2001	MSP3400CPPC6	AUDIO PROCESSOR
IC251	TDA2030AV	AUDIO AMPLIFIER
IC252	TDA2030AV	AUDIO AMPLIFIER
IC3101	TEA6420	AUDIO SWITCH
IC3102	TEA6415C	VIDEO SWITCH
IC3501	SDA5273S/134	MEGA TEXT
IC3502	M514256B70RS	DRAM
IC351	TDA6111	RGB OUTPUT
IC361	TDA6111	RGB OUTPUT
IC371	TDA6111	RGB OUTPUT
IC3801	AN7808LB	8V REGULATOR
IC3803	AN7805LB	5V REGULATOR
IC3804	AN7809FLB	9V REGULATOR
IC3805	AN78L08TA	8V REGULATOR
IC401	TDA9151-B	DEFLECTION CONTROL
IC451	TDA8350Q/N5	VERTICAL OUTPUT
IC601	TDA9143-N1	COLOUR DECODER
IC602	TDA4665-V4	DELAY LINE
IC845	SE140N	ERROR AMPLIFIER
IC851	TL431ACLPM	COIL
IC852	TL431ACLPM	COIL

TERMINALS AND LINKS

JA2	ERJ6GEY0R00	S.M.CARB	0.1W	5%	0Ω
JA3	ERJ6GEY0R00	S.M.CARB	0.1W	5%	0Ω
JA5	ERJ6GEY0R00	S.M.CARB	0.1W	5%	0Ω
JA6	ERJ6GEY0R00	S.M.CARB	0.1W	5%	0Ω
JA7	ERJ6GEY0R00	S.M.CARB	0.1W	5%	0Ω
JA8	ERJ6GEY0R00	S.M.CARB	0.1W	5%	0Ω
JA9	ERJ6GEY0R00	S.M.CARB	0.1W	5%	0Ω
JK3001	TJBA039	A/V TERMINAL			
JSB3	ERJ6GEY0R00	S.M.CARB	0.1W	5%	0Ω
JSE010	ERJ6GEY0R00	S.M.CARB	0.1W	5%	0Ω
JSE011	ERJ6GEY0R00	S.M.CARB	0.1W	5%	0Ω
JSE012	ERJ6GEY0R00	S.M.CARB	0.1W	5%	0Ω
JSE015	ERJ6GEY0R00	S.M.CARB	0.1W	5%	0Ω
JSE022	ERJ6GEY0R00	S.M.CARB	0.1W	5%	0Ω
JSE023	ERJ6GEY0R00	S.M.CARB	0.1W	5%	0Ω
JSE024	ERJ6GEY0R00	S.M.CARB	0.1W	5%	0Ω
JSE025	ERJ6GEY0R00	S.M.CARB	0.1W	5%	0Ω
JSE028	ERJ6GEY0R00	S.M.CARB	0.1W	5%	0Ω
JSE03	ERJ6GEY0R00	S.M.CARB	0.1W	5%	0Ω
JSE042	ERJ6GEY0R00	S.M.CARB	0.1W	5%	0Ω
JSE050	ERJ6GEY0R00	S.M.CARB	0.1W	5%	0Ω
JSE056	ERJ6GEY0R00	S.M.CARB	0.1W	5%	0Ω
JSE057	ERJ6GEY0R00	S.M.CARB	0.1W	5%	0Ω
JSE058	ERJ6GEY0R00	S.M.CARB	0.1W	5%	0Ω
JSE062	ERJ6GEY0R00	S.M.CARB	0.1W	5%	0Ω
JSE064	ERJ6GEY0R00	S.M.CARB	0.1W	5%	0Ω
JSE066	ERJ6GEY0R00	S.M.CARB	0.1W	5%	0Ω
JSE07	ERJ6GEY0R00	S.M.CARB	0.1W	5%	0Ω
JSE09	ERJ6GEY0R00	S.M.CARB	0.1W	5%	0Ω
JSF001	ERJ6GEY0R00	S.M.CARB	0.1W	5%	0Ω
JSF002	ERJ6GEY0R00	S.M.CARB	0.1W	5%	0Ω
JSF003	ERJ6GEY0R00	S.M.CARB	0.1W	5%	0Ω
JSF004	ERJ6GEY0R00	S.M.CARB	0.1W	5%	0Ω
JSF005	ERJ6GEY0R00	S.M.CARB	0.1W	5%	0Ω
JSF006	ERJ6GEY0R00	S.M.CARB	0.1W	5%	0Ω
JSF008	ERJ6GEY0R00	S.M.CARB	0.1W	5%	0Ω
JSF011	ERJ6GEY0R00	S.M.CARB	0.1W	5%	0Ω
JSF012	ERJ6GEY0R00	S.M.CARB	0.1W	5%	0Ω
JSF014	ERJ6GEY0R00	S.M.CARB	0.1W	5%	0Ω
JSF015	ERJ6GEY0R00	S.M.CARB	0.1W	5%	0Ω
JSF026	ERJ6GEY0R00	S.M.CARB	0.1W	5%	0Ω
JSF036	ERJ6GEY0R00	S.M.CARB	0.1W	5%	0Ω
JSF039	ERJ6GEY0R00	S.M.CARB	0.1W	5%	0Ω

Ref No.	Part No.	Description
JSF040	ERJ6GEY0R00	S.M.CARB 0.1W 5% 0Ω
JSF041	ERJ6GEY0R00	S.M.CARB 0.1W 5% 0Ω
JSF042	ERJ6GEY0R00	S.M.CARB 0.1W 5% 0Ω
JSF044	ERJ6GEY0R00	S.M.CARB 0.1W 5% 0Ω
JSF045	ERJ6GEY0R00	S.M.CARB 0.1W 5% 0Ω
JSF046	ERJ6GEY0R00	S.M.CARB 0.1W 5% 0Ω
JSF048	ERJ6GEY0R00	S.M.CARB 0.1W 5% 0Ω
JSF049	ERJ6GEY0R00	S.M.CARB 0.1W 5% 0Ω
JSF050	ERJ6GEY0R00	S.M.CARB 0.1W 5% 0Ω
JSF051	ERJ6GEY0R00	S.M.CARB 0.1W 5% 0Ω
JSF055	ERJ6GEY0R00	S.M.CARB 0.1W 5% 0Ω
JSF056	ERJ6GEY0R00	S.M.CARB 0.1W 5% 0Ω
JSF057	ERJ6GEY0R00	S.M.CARB 0.1W 5% 0Ω
JSF064	ERJ6GEY0R00	S.M.CARB 0.1W 5% 0Ω
JSF066	ERJ6GEY0R00	S.M.CARB 0.1W 5% 0Ω
JSF072	ERJ6GEY0R00	S.M.CARB 0.1W 5% 0Ω
JSF073	ERJ6GEY0R00	S.M.CARB 0.1W 5% 0Ω
JSF075	ERJ6GEY0R00	S.M.CARB 0.1W 5% 0Ω
JSF076	ERJ6GEY0R00	S.M.CARB 0.1W 5% 0Ω
JSF077	ERJ6GEY0R00	S.M.CARB 0.1W 5% 0Ω
JSF080	ERJ6GEY0R00	S.M.CARB 0.1W 5% 0Ω
JSF081	ERJ6GEY0R00	S.M.CARB 0.1W 5% 0Ω
JSF086	ERJ6GEY0R00	S.M.CARB 0.1W 5% 0Ω
JSF087	ERJ6GEY0R00	S.M.CARB 0.1W 5% 0Ω
JSF088	ERJ6GEY0R00	S.M.CARB 0.1W 5% 0Ω
JSF089	ERJ6GEY0R00	S.M.CARB 0.1W 5% 0Ω
JSF090	ERJ6GEY0R00	S.M.CARB 0.1W 5% 0Ω
JSF091	ERJ6GEY0R00	S.M.CARB 0.1W 5% 0Ω
JSH004	ERJ6GEY0R00	S.M.CARB 0.1W 5% 0Ω
JSH005	ERJ6GEY0R00	S.M.CARB 0.1W 5% 0Ω
JSH01	ERJ6GEY0R00	S.M.CARB 0.1W 5% 0Ω
JSH010	ERJ6GEY0R00	S.M.CARB 0.1W 5% 0Ω
JSH02	ERJ6GEY0R00	S.M.CARB 0.1W 5% 0Ω

COILS

LC1507	EXCEMT103DTM	COIL
LC1508	EXCEMT103DTM	COIL
LC1509	EXCEMT103DTM	COIL
LC1510	EXCEMT103DTM	COIL
LC1610	ELKTR560BA	DELAY LINE
L002	TLT047K991R	COIL
L004	TLT047K991R	COIL
L005	TLT047K991R	COIL
L102	TLT056K991R	COIL
L103	EQV7EN203B	COIL
L105	ELESNR22MA	COIL
L107	ELESNR22MA	COIL
L108	ELESNR22MA	COIL
L109	EIL7EN015Q	COIL
L110	EQL7EN022Q	COIL
L113	EIL7EN015Q	COIL
L252	EXCELSA35T	COIL
L253	EXCELSA35T	COIL
L254	EXCELSA35T	COIL
L255	EXCELSA35T	COIL
L351	SDL5000	DELAY LINE
L352	EXCELDLDR25V	COIL
L353	TLT150K991R	COIL
L361	SDL5000	DELAY LINE
L362	EXCELDLDR25V	COIL
L363	TLT150K991R	COIL
L371	SDL5000	DELAY LINE
L372	EXCELDLDR25V	COIL
L373	TLT150K991R	COIL
L381	TLT220K991R	COIL
L401	EXCELDLDR35V	COIL
L402	EXCELDLDR35V	COIL
L451	EXCELDLDR35V	COIL
L552	EXCELSA35T	COIL
L553	EXCELSA35T	COIL
L554	EXCELDLDR35V	COIL
L555	ERD25TCOT	CARBON 0.25W 5% 0Ω
L556	EXCELSA24T	COIL

Ref No.	Part No.	Description
L557	EXCELSA24T	COIL
L571	ELC18B221L	COIL
L572	ELHKL025B	COIL
L573	ELHKL026B	COIL
L575	ELC18B271E	COIL
L601	TLT047K991R	COIL
L602	TLT047K991R	COIL
L603	TLT047K991R	COIL
L605	EXCELD35V	COIL
L801	ELF18D424F	COIL
L802	ELF18D424F	COIL
L807	ELF18D860D	LINE FILTER
L808	EXCELSA35T	COIL
L809	EXCELD35V	COIL
L810	EXCELSA39V	COIL
L811	EXCELSA39V	COIL
L812	EXCELD35V	COIL
L813	EXCELD35V	COIL
L817	EXCELD35V	COIL
L845	EXCELSA35T	COIL
L847	EXCELSA35B	COIL
L848	EXCELSA35T	COIL
L850	EXCELSA35T	COIL
L851	EXCELSA35B	COIL
L852	EXCELSA35T	COIL
L853	EXCELSA35T	COIL
L854	ELEIE150KA	COIL
L856	EXCELSA35T	COIL
L861	EXCELSA35T	COIL
L862	EXCELSA35T	COIL
L864	EXCELD35V	COIL
L1102	EXCELD35V	COIL
L1103	EXCELD35V	COIL
L1104	EXCELSA35T	COIL
L1105	ELEXT4R7KA	COIL
L1302	TLT100K991R	COIL
L1304	TLT100K991R	COIL
L1307	ERD25TC0T	CARBON 0.25W 5% 0Ω
L1501	EXCELD35V	COIL
L1504	TLT018K991R	COIL
L1505	ELESN120JA	COIL
L1506	ELESN120JA	COIL
L1507	ELESN3R3JA	COIL
L1552	EXCELD35V	COIL
L1553	EXCELD35V	COIL
L1575	EXCELD35V	COIL
L1576	EXCELD35V	COIL
L1601	EXCELD35V	COIL
L1602	EXCELD35V	COIL
L1603	TLT100K991R	COIL
L1604	TLT100K991R	COIL
L1605	TLT100K991R	COIL
L1606	TLT100K991R	COIL
L1607	EXCELD35V	COIL
L1621	ELESN3R3JA	COIL
L1622	ELESN3R3JA	COIL
L1623	TLT022K991R	COIL
L1641	EXCELD35V	COIL
L1701	EXCELD35V	COIL
L2001	TLT047K991R	COIL
L2002	TLT100K991R	COIL
L2003	EXCELD35V	COIL
L2004	TLT068K991R	COIL
L2005	TLT068K991R	COIL
L2351	ELEBR6R8KA	COIL
L2361	ELEBR6R8KA	COIL
L3001	ELEBR6R8KA	COIL
L3002	ELEBR6R8KA	COIL
L3003	ELEBR470KA	COIL
L3107	EXCELD35V	COIL
L3108	EXCELD35V	COIL
L3109	EXCELD35V	COIL
L3110	EXCELD35V	COIL

Ref No.	Part No.	Description
L3111	EXCELD35V	COIL
L3112	EXCELD35V	COIL
L3113	EXCELD35V	COIL
L3114	EXCELD35V	COIL
L3503	EXCELD35V	COIL
L3507	EXCELD35V	COIL
L3509	EXCELD35V	COIL
L3511	TLT100K991R	COIL
TRANSISTORS		
Q008	BC847B	TRANSISTOR OR 2SD601ATX
Q101	BC847B	TRANSISTOR OR 2SD601ATX
Q102	BC847B	TRANSISTOR OR 2SD601ATX
Q103	BC847B	TRANSISTOR OR 2SD601ATX
Q104	BC847B	TRANSISTOR OR 2SD601ATX
Q105	BC847B	TRANSISTOR OR 2SD601ATX
Q106	BF799E6327	CHIPTRANSISTOR
Q107	BC847B	TRANSISTOR OR 2SD601ATX
Q108	BC847B	TRANSISTOR OR 2SD601ATX
Q109	BC860B	TRANSISTOR
Q251	BC847B	TRANSISTOR OR 2SD601ATX
Q252	BC847B	TRANSISTOR OR 2SD601ATX
Q401	BC847B	TRANSISTOR OR 2SD601ATX
Q502	2SC2925STA	TRANSISTOR
Q531	BC547B	TRANSISTOR
Q532	BC547B	TRANSISTOR
Q533	BC547B	TRANSISTOR
Q535	BC547B	TRANSISTOR
Q551	BC547B	TRANSISTOR
Q552	2SC5418001TV	TRANSISTOR
Q553	2SC1473-RN	TRANSISTOR
Q554	2SC1473-RN	TRANSISTOR
Q573	BC557B	TRANSISTOR
Q574	2SD1265AOPLB	TRANSISTOR
Q601	BC847B	TRANSISTOR OR 2SD601ATX
Q602	BC857B	TRANSISTOR OR 2SB709ATX
Q603	BC847B	TRANSISTOR OR 2SD601ATX
Q604	BC857B	TRANSISTOR OR 2SB709ATX
Q605	BC857B	TRANSISTOR OR 2SB709ATX
Q606	BC847B	TRANSISTOR OR 2SD601ATX
Q607	BC847B	TRANSISTOR OR 2SD601ATX
Q608	BC847B	TRANSISTOR OR 2SD601ATX
Q609	BC847B	TRANSISTOR OR 2SD601ATX
Q610	BC847B	TRANSISTOR OR 2SD601ATX
Q611	BC847B	TRANSISTOR OR 2SD601ATX
Q612	BC847B	TRANSISTOR OR 2SD601ATX
Q801	2SK1365LBMAT	TRANSISTOR
Q803	2SD965-R	TRANSISTOR
Q804	2SA719-TA	TRANSISTOR
Q845	2SA684R	TRANSISTOR
Q846	BC547B	TRANSISTOR
Q847	BC557B	TRANSISTOR
Q848	BC547B	TRANSISTOR
Q849	2SA1018QTA	TRANSISTOR
Q850	2SD1474PLB	TRANSISTOR
Q851	BC547B	TRANSISTOR
Q852	BC547B	TRANSISTOR
Q901	BC847B	TRANSISTOR OR 2SD601ATX
Q902	BC847B	TRANSISTOR OR 2SD601ATX
Q903	BC847B	TRANSISTOR OR 2SD601ATX
Q904	BC857B	TRANSISTOR OR 2SB709ATX
Q905	BC847B	TRANSISTOR OR 2SD601ATX
Q906	BC847B	TRANSISTOR OR 2SD601ATX
Q907	BC857B	TRANSISTOR OR 2SB709ATX
Q908	2SA1535ARLB	TRANSISTOR
Q909	2SC3944ARLB	TRANSISTOR
Q1052	BC557B	TRANSISTOR
Q1101	BC847B	TRANSISTOR OR 2SD601ATX
Q1102	BC847B	TRANSISTOR OR 2SD601ATX
Q1103	BC847B	TRANSISTOR OR 2SD601ATX
Q1108	BC847B	TRANSISTOR OR 2SD601ATX
Q1112	2SC3757QRTX	TRANSISTOR

Ref No.	Part No.	Description
Q1191	BC847B	TRANSISTOR OR 2SD601ATX
Q1301	BC847B	TRANSISTOR OR 2SD601ATX
Q1303	BC847B	TRANSISTOR OR 2SD601ATX
Q1501	BC847B	TRANSISTOR OR 2SD601ATX
Q1502	BC847B	TRANSISTOR OR 2SD601ATX
Q1503	BC847B	TRANSISTOR OR 2SD601ATX
Q1505	BC847B	TRANSISTOR OR 2SD601ATX
Q1561	BC847B	TRANSISTOR OR 2SD601ATX
Q1575	BC847B	TRANSISTOR OR 2SD601ATX
Q1635	BC857B	TRANSISTOR OR 2SB709ATX
Q1636	BC857B	TRANSISTOR OR 2SB709ATX
Q1642	BC847B	TRANSISTOR OR 2SD601ATX
Q1643	BC847B	TRANSISTOR OR 2SD601ATX
Q1644	BC857B	TRANSISTOR OR 2SB709ATX
Q1647	BC847B	TRANSISTOR OR 2SD601ATX
Q1648	BC857B	TRANSISTOR OR 2SB709ATX
Q1649	BC857B	TRANSISTOR OR 2SB709ATX
Q1650	BC857B	TRANSISTOR OR 2SB709ATX
Q2001	BC860B	TRANSISTOR
Q2002	BC860B	TRANSISTOR
Q2003	BC860B	TRANSISTOR
Q2004	BC860B	TRANSISTOR
Q2006	BC857B	TRANSISTOR OR 2SB709ATX
Q2007	BC847B	TRANSISTOR OR 2SD601ATX
Q2351	BC547B	TRANSISTOR
Q2352	BC547B	TRANSISTOR
Q2353	BC557B	TRANSISTOR
Q2361	BC547B	TRANSISTOR
Q2362	BC547B	TRANSISTOR
Q2363	BC557B	TRANSISTOR
Q3101	BC847B	TRANSISTOR OR 2SD601ATX
Q3102	BC847B	TRANSISTOR OR 2SD601ATX
Q3105	BC847B	TRANSISTOR OR 2SD601ATX
Q3106	BC847B	TRANSISTOR OR 2SD601ATX
Q3107	BC857B	TRANSISTOR OR 2SB709ATX
Q3108	BC847B	TRANSISTOR OR 2SD601ATX
Q3113	BC847B	TRANSISTOR OR 2SD601ATX
Q3115	BC857B	TRANSISTOR OR 2SB709ATX
Q3201	BC847B	TRANSISTOR OR 2SD601ATX
Q3351	BC847B	TRANSISTOR OR 2SD601ATX
Q3352	BC857B	TRANSISTOR OR 2SB709ATX
Q3501	BC847B	TRANSISTOR OR 2SD601ATX
Q3502	BC847B	TRANSISTOR OR 2SD601ATX
Q3503	2SC3130TX	TRANSISTOR
Q3801	2SD1474PLB	TRANSISTOR

RESISTOR

RL806	TSE1885-1	TRANSISTOR
R003	ERJ6GEYJ223	S.M.CARB 0.1W 5% 22KΩ
R006	ERJ6GEYJ393	S.M.CARB 0.1W 5% 39KΩ
R011	ERJ6GEYJ101	S.M.CARB 0.1W 5% 100Ω
R012	ERJ6GEYJ101	S.M.CARB 0.1W 5% 100Ω
R101	ERJ6GEYJ102	S.M.CARB 0.1W 5% 1KΩ
R102	ERJ6GEYJ101	S.M.CARB 0.1W 5% 100Ω
R103	ERJ6GEYJ103	S.M.CARB 0.1W 5% 10KΩ
R104	ERJ6GEY0R00	S.M.CARB 0.1W 5% 0Ω
R105	ERJ6GEYJ331	S.M.CARB 0.1W 5% 330Ω
R106	ERJ6GEYJ680	S.M.CARB 0.1W 5% 68Ω
R107	ERJ6GEYJ123	S.M.CARB 0.1W 5% 12KΩ
R109	ERJ6GEYJ102	S.M.CARB 0.1W 5% 1KΩ
R110	ERJ6GEYJ103	S.M.CARB 0.1W 5% 10KΩ
R111	ERJ6GEYJ331	S.M.CARB 0.1W 5% 330Ω
R113	ERJ6GEY0R00	S.M.CARB 0.1W 5% 0Ω
R115	ERJ6GEYJ121	S.M.CARB 0.1W 5% 120Ω
R117	ERJ6GEYJ683	S.M.CARB 0.1W 5% 68KΩ
R118	ERJ6GEYJ151	S.M.CARB 0.1W 5% 150Ω
R119	ERJ6GEY0R00	S.M.CARB 0.1W 5% 0Ω
R120	ERJ6GEYJ223	S.M.CARB 0.1W 5% 22KΩ
R121	ERJ6GEYJ331	S.M.CARB 0.1W 5% 330Ω
R122	EVNDXAA03B24	CONTROL 20KΩ
R123	ERJ6GEYJ104	S.M.CARB 0.1W 5% 100KΩ
R124	ERJ6GEYJ223	S.M.CARB 0.1W 5% 22KΩ
R125	ERJ6GEYJ101	S.M.CARB 0.1W 5% 100Ω

Ref No.	Part No.	Description
R126	ERJ6GEYJ223	S.M.CARB 0.1W 5% 22KΩ
R127	ERJ6GEYJ473	S.M.CARB 0.1W 5% 47KΩ
R128	ERJ6GEYJ181	S.M.CARB 0.1W 5% 180Ω
R130	ERJ6GEY0R00	S.M.CARB 0.1W 5% 0Ω
R132	ERJ6GEYJ122	S.M.CARB 0.1W 5% 1K2Ω
R133	ERJ6GEYJ122	S.M.CARB 0.1W 5% 1K2Ω
R134	ERJ6GEYJ103	S.M.CARB 0.1W 5% 10KΩ
R135	ERJ6GEYJ103	S.M.CARB 0.1W 5% 10KΩ
R136	ERJ6GEYJ122	S.M.CARB 0.1W 5% 1K2Ω
R137	ERJ6GEYJ104	S.M.CARB 0.1W 5% 100KΩ
R138	ERJ6GEYJ122	S.M.CARB 0.1W 5% 1K2Ω
R139	ERJ6GEYJ154	S.M.CARB 0.1W 5% 150KΩ
R141	ERJ6GEYJ330	S.M.CARB 0.1W 5% 33Ω
R142	ERJ6GEYJ271	S.M.CARB 0.1W 5% 270Ω
R143	ERJ6GEYJ123	S.M.CARB 0.1W 5% 12KΩ
R144	ERJ6GEYJ152	S.M.CARB 0.1W 5% 1K5Ω
R145	ERJ6GEYJ331	S.M.CARB 0.1W 5% 330Ω
R146	ERJ6GEYJ104	S.M.CARB 0.1W 5% 100KΩ
R147	ERJ6GEYJ122	S.M.CARB 0.1W 5% 1K2Ω
R148	ERJ6GEYJ183	S.M.CARB 0.1W 5% 18KΩ
R149	ERJ6GEYJ682	S.M.CARB 0.1W 5% 6K8Ω
R150	ERJ6GEYJ221	S.M.CARB 0.1W 5% 220Ω
R151	ERJ6GEYJ471	S.M.CARB 0.1W 5% 470Ω
R152	ERJ6GEYJ103	S.M.CARB 0.1W 5% 10KΩ
R154	ERJ6GEY0R00	S.M.CARB 0.1W 5% 0Ω
R156	ERJ6GEY0R00	S.M.CARB 0.1W 5% 0Ω
R157	ERJ6GEYJ101	S.M.CARB 0.1W 5% 100Ω
R159	ERJ6GEYJ153	S.M.CARB 0.1W 5% 15KΩ
R251	ERJ6GEYJ2R2	SM.CARB0.125W 5% 2R2Ω
R252	ERJ6GEYJ153	S.M.CARB 0.1W 5% 15KΩ
R253	ERJ6GEY0R00	S.M.CARB 0.1W 5% 0Ω
R254	ERJ6GEYJ223	S.M.CARB 0.1W 5% 22KΩ
R255	ERJ6GEYJ331	S.M.CARB 0.1W 5% 330Ω
R256	ERJ6GEYJ104	S.M.CARB 0.1W 5% 100KΩ
R257	ERJ6GEYJ102	S.M.CARB 0.1W 5% 1KΩ
R258	ERJ6GEYJ471	S.M.CARB 0.1W 5% 470Ω
R259	ERG3SJS120	METAL 3W 5% 12Ω ▲
R260	ERJ6GEYJ2R2	SM.CARB0.125W 5% 2R2Ω
R261	ERJ6GEYJ153	S.M.CARB 0.1W 5% 15KΩ
R262	ERJ6GEYJ223	S.M.CARB 0.1W 5% 22KΩ
R263	ERJ6GEYJ331	S.M.CARB 0.1W 5% 330Ω
R264	ERJ6GEYJ104	S.M.CARB 0.1W 5% 100KΩ
R265	ERJ6GEYJ471	S.M.CARB 0.1W 5% 470Ω
R266	ERJ6GEYJ102	S.M.CARB 0.1W 5% 1KΩ
R267	ERJ6GEYJ151	S.M.CARB 0.1W 5% 150Ω
R268	ERJ6GEYJ151	S.M.CARB 0.1W 5% 150Ω
R269	ERJ6GEY0R00	S.M.CARB 0.1W 5% 0Ω
R270	ERG3SJS120	METAL 3W 2% 12Ω ▲
R350	ERQ12AJ151P	FUSABLE 12W 5% 150Ω ▲
R351	ERJ6GEYJ102	S.M.CARB 0.1W 5% 1KΩ
R352	ERJ6GEYJ102	S.M.CARB 0.1W 5% 1KΩ
R354	ERJ6GEYJ102	S.M.CARB 0.1W 5% 1KΩ
R355	ERG2FJ823	METAL 2W 5% 82KΩ ▲
R356	ERJ6GEY0R00	S.M.CARB 0.1W 5% 0Ω
R357	ERJ6GEYJ822	S.M.CARB 0.1W 5% 8K2Ω
R358	ERDS1TJ821	CARBON 0.5W 5% 820Ω
R359	ERJ6GEYJ334	S.M.CARB 0.1W 5% 330KΩ
R360	ERDS1TJ103	CARBON 0.5W 5% 10KΩ
R361	ERJ6GEYJ102	S.M.CARB 0.1W 5% 1KΩ
R362	ERJ6GEYJ102	S.M.CARB 0.1W 5% 1KΩ
R364	ERJ6GEYJ102	S.M.CARB 0.1W 5% 1KΩ
R365	ERG2FJ823	METAL 2W 5% 82KΩ ▲
R366	ERJ6GEY0R00	S.M.CARB 0.1W 5% 0Ω
R367	ERJ6GEYJ822	S.M.CARB 0.1W 5% 8K2Ω
R368	ERDS1TJ821	CARBON 0.5W 5% 820Ω
R369	ERJ6GEY0R00	S.M.CARB 0.1W 5% 0Ω
R371	ERJ6GEYJ102	S.M.CARB 0.1W 5% 1KΩ
R372	ERJ6GEYJ102	S.M.CARB 0.1W 5% 1KΩ
R374	ERJ6GEYJ102	S.M.CARB 0.1W 5% 1KΩ
R375	ERG2FJ823	METAL 2W 5% 82KΩ ▲
R376	ERJ6GEY0R00	S.M.CARB 0.1W 5% 0Ω
R377	ERJ6GEYJ822	S.M.CARB 0.1W 5% 8K2Ω
R378	ERDS1TJ821	CARBON 0.5W 5% 820Ω

Ref No.	Part No.	Description				
R818	ERD25TJ331	CARBON 0.25W	5%	330Ω		
R820	ERG3FJ223	METAL 3W	5%	22KΩ	△	
R821	ERG3FJ223	METAL 3W	5%	22KΩ	△	
R822	ERD25TJ391	CARBON 0.25W	5%	390Ω		
R823	ERX2SJR22	RESISTOR 2W	5%	R22Ω		
R824	ERX2SJR22	RESISTOR 2W	5%	R22Ω		
R825	ERX2SJR22	RESISTOR 2W	5%	R22Ω		
R827	ERDS1FJ100	CARBON 0.5W	5%	10Ω		
R828	ERD25TJ103	CARBON 0.25W	5%	10KΩ		
R829	ERD25TJ471	CARBON 0.25W	5%	470Ω		
R831	ERD75TAJ825	CARBON 0.75W	5%	8M2Ω	△	
R832	ERG1SJ331	METAL 1W	5%	330Ω	△	
R835	ERD25TJ220	CARBON 0.25W	5%	22Ω		
R836	ERD25TJ100	CARBON 0.25W	5%	10Ω		
R837	ERD25TJ153	CARBON 0.25W	5%	15KΩ		
R838	ERD25TJ102	CARBON 0.25W	5%	1KΩ		
R847	ERQ1CKPR82	METAL 1W	5%	R82Ω	△	
R853	ERO25CKF1002	METAL 0.25W	1%	10KΩ	△	
R854	ERDS1TJ153	CARBON 0.5W	5%	15KΩ		
R855	ERD25TJ472	CARBON 0.25W	5%	4K7Ω		
R856	ERD25TJ473	CARBON 0.25W	5%	47KΩ		
R858	ERO25CKF1002	METAL 0.25W	1%	10KΩ	△	
R862	ERD25TJ472	CARBON 0.25W	5%	4K7Ω		
R863	ERG3FJ680	METAL 3W	5%	68Ω	△	
R864	ERDS1TJ103	CARBON 0.5W	5%	10KΩ		
R865	ERG3FJ680	METAL 3W	5%	68Ω	△	
R867	ERD25TJ102	CARBON 0.25W	5%	1KΩ		
R870	ERD25TJ101	CARBON 0.25W	5%	100Ω		
R873	ERDS1TJ3R3	CARBON 0.5W	5%	3R3Ω		
R876	ERD25TJ562	CARBON 0.25W	5%	5K6Ω		
R877	ERO25CKF1052	METAL 25W	1%	10KΩ	△	
R878	ERO25CKF1002	METAL 0.25W	1%	10KΩ	△	
R883	ERD25TJ103	CARBON 0.25W	5%	10KΩ		
R885	ERD25TJ103	CARBON 0.25W	5%	10KΩ		
R886	ERF10ZK4R7	WOUND 10W	5%	4R7Ω	△	
R888	ERDS1TJ393	CARBON 0.5W	5%	39KΩ		
R889	ERD25TJ392	CARBON 0.25W	5%	3K9Ω		
R890	ERX3SJR56	RESISTOR 3W	5%	R56Ω		
R891	ERD25TJ103	CARBON 0.25W	5%	10KΩ		
R892	ERD25TJ222	CARBON 0.25W	5%	2K2Ω		
R897	ERO25CKF1503	METAL 0.25W	1%	15Ω	△	
R898	ERO25CKF1002	METAL 0.25W	1%	10KΩ	△	
R905	ERJ6GEYJ681	S.M.CARB 0.1W	5%	680Ω		
R906	ERJ6GEYJ393	S.M.CARB 0.1W	5%	39KΩ		
R907	ERJ6GEYJ822	S.M.CARB 0.1W	5%	8K2Ω		
R908	ERJ6GEYJ471	S.M.CARB 0.1W	5%	470Ω		
R909	ERJ6GEYJ102	S.M.CARB 0.1W	5%	1KΩ		
R910	ERJ6GEYJ221	S.M.CARB 0.1W	5%	220Ω		
R911	ERD25TJ561	CARBON 0.25W	5%	560Ω		
R913	ERJ6GEYJ153	S.M.CARB 0.1W	5%	15KΩ		
R914	ERJ6GEYJ222	S.M.CARB 0.1W	5%	2K2Ω		
R915	ERJ6GEYJ681	S.M.CARB 0.1W	5%	680Ω		
R916	ERJ6GEYJ331	S.M.CARB 0.1W	5%	330Ω		
R918	ERJ6GEYJ101	S.M.CARB 0.1W	5%	100Ω		
R919	ERQ14AJW390	FUSABLE 14W	2%	39Ω	△	
R920	ERQ14AJW390	FUSABLE 14W	2%	39Ω	△	
R922	ERD25TJ683	CARBON 0.25W	5%	68KΩ		
R923	ERD25TJ683	CARBON 0.25W	5%	68KΩ		
R924	ERDS1FYJ390	CARBON 0.5W	5%	39Ω	△	
R925	ERJ6GEYOR00	S.M.CARB 0.1W	5%	0Ω		
R926	ERJ6GEYOR00	S.M.CARB 0.1W	5%	0Ω		
R927	ERD25TJ122	CARBON 0.25W	5%	1K2Ω		
R928	ERD25TJ2R7	CARBON 0.25W	5%	2R7Ω		
R929	ERDS1FYJ221	CARBON 0.5W	5%	220Ω		
R930	ERD25TJ2R7	CARBON 0.25W	5%	2R7Ω		
R931	ERDS1FYJ390	CARBON 0.5W	5%	39Ω	△	
R932	ERDS1FYJ101	CARBON 0.5W	5%	100Ω	△	
R933	ERJ6GEYJ223	S.M.CARB 0.1W	5%	22KΩ		
R934	ERJ6GEYJ472	S.M.CARB 0.1W	5%	4K7Ω		
R935	ERQ14AJW3R9	FUSABLE 14W	2%	3R9Ω	△	
R936	ERQ1CJP102	METAL 1W	5%	1KΩ	△	
R937	ERQ14AJW100	METAL 0.25W	5%	10Ω	△	

Ref No.	Part No.	Description				
R938	ERD25TJ122	CARBON 0.25W	5%	1K2Ω		
R940	ERD25TJ3R3	CARBON 0.25W	5%	3R3Ω		
R941	ERD25TJ3R3	CARBON 0.25W	5%	3R3Ω		
R1054	ERD25TJ101	CARBON 0.25W	5%	100Ω		
R1057	ERD25TJ101	CARBON 0.25W	5%	100Ω		
R1058	ERD25TJ471	CARBON 0.25W	5%	470Ω		
R1059	ERD25TJ103	CARBON 0.25W	5%	10KΩ		
R1061	ERD25TJ103	CARBON 0.25W	5%	10KΩ		
R1062	ERD25TJ222	CARBON 0.25W	5%	2K2Ω		
R1063	ERD25TJ222	CARBON 0.25W	5%	2K2Ω		
R1064	ERD25TJ332	CARBON 0.25W	5%	3K3Ω		
R1065	ERD25TJ512	CARBON 0.25W	5%	5K1Ω		
R1066	ERD25TJ912	CARBON 0.25W	5%	9K1Ω		
R1101	ERJ6GEYJ472	S.M.CARB 0.1W	5%	4K7Ω		
R1102	ERJ6GEYJ472	S.M.CARB 0.1W	5%	4K7Ω		
R1103	ERJ6GEYJ472	S.M.CARB 0.1W	5%	4K7Ω		
R1104	ERJ6GEYJ472	S.M.CARB 0.1W	5%	4K7Ω		
R1105	ERJ6GEYJ472	S.M.CARB 0.1W	5%	4K7Ω		
R1106	ERJ6GEYJ472	S.M.CARB 0.1W	5%	4K7Ω		
R1107	ERJ6GEYJ472	S.M.CARB 0.1W	5%	4K7Ω		
R1108	ERJ6GEYJ472	S.M.CARB 0.1W	5%	4K7Ω		
R1111	ERJ6GEYJ101	S.M.CARB 0.1W	5%	100Ω		
R1112	ERJ6GEYJ101	S.M.CARB 0.1W	5%	100Ω		
R1113	ERJ6GEYJ101	S.M.CARB 0.1W	5%	100Ω		
R1116	ERJ6GEYJ101	S.M.CARB 0.1W	5%	100Ω		
R1117	ERJ6GEYJ101	S.M.CARB 0.1W	5%	100Ω		
R1118	ERJ6GEYJ101	S.M.CARB 0.1W	5%	100Ω		
R1119	ERJ6GEYJ101	S.M.CARB 0.1W	5%	100Ω		
R1120	ERJ6GEYJ101	S.M.CARB 0.1W	5%	100Ω		
R1121	ERJ6GEYJ101	S.M.CARB 0.1W	5%	100Ω		
R1122	ERJ6GEYJ101	S.M.CARB 0.1W	5%	100Ω		
R1123	ERJ6GEYJ472	S.M.CARB 0.1W	5%	4K7Ω		
R1124	ERJ6GEYJ103	S.M.CARB 0.1W	5%	10KΩ		
R1125	ERJ6GEYJ103	S.M.CARB 0.1W	5%	10KΩ		
R1126	ERJ6GEYJ101	S.M.CARB 0.1W	5%	100Ω		
R1127	ERJ6GEYJ101	S.M.CARB 0.1W	5%	100Ω		
R1128	ERJ6GEYJ100	S.M.CARB 0.1W	5%	10Ω		
R1129	ERJ6GEYJ100	S.M.CARB 0.1W	5%	10Ω		
R1133	ERJ6GEYJ103	S.M.CARB 0.1W	5%	10KΩ		
R1134	ERJ6GEYJ103	S.M.CARB 0.1W	5%	10KΩ		
R1135	ERJ6GEYOR00	S.M.CARB 0.1W	5%	0Ω		
R1136	ERJ6GEYJ221	S.M.CARB 0.1W	5%	220Ω		
R1137	ERJ6GEYJ561	S.M.CARB 0.1W	5%	560Ω		
R1138	ERJ6GEYJ103	S.M.CARB 0.1W	5%	10KΩ		
R1142	ERJ6GEYJ103	S.M.CARB 0.1W	5%	10KΩ		
R1145	ERJ6GEYJ472	S.M.CARB 0.1W	5%	4K7Ω		
R1150	ERJ6GEYJ472	S.M.CARB 0.1W	5%	4K7Ω		
R1151	ERJ6GEYJ472	S.M.CARB 0.1W	5%	4K7Ω		
R1152	ERJ6GEYJ472	S.M.CARB 0.1W	5%	4K7Ω		
R1153	ERJ6GEYJ472	S.M.CARB 0.1W	5%	4K7Ω		
R1154	ERJ6GEYJ472	S.M.CARB 0.1W	5%	4K7Ω		
R1156	ERJ6GEYJ182	S.M.CARB 0.1W	5%	1K8Ω		
R1163	ERJ6GEYJ152	S.M.CARB 0.1W	5%	1K5Ω		
R1164	ERJ6GEYJ101	S.M.CARB 0.1W	5%	100Ω		
R1169	ERJ6GEYJ102	S.M.CARB 0.1W	5%	1KΩ		
R1170	ERJ6GEYJ332	S.M.CARB 0.1W	5%	3K3Ω		
R1171	ERJ6GEYJ682	S.M.CARB 0.1W	5%	6K8Ω		
R1172	ERJ6GEYJ561	S.M.CARB 0.1W	5%	560Ω		
R1174	ERDS1TJ561	CARBON 0.5W	5%	560Ω		
R1182	ERJ6GEYJ472	S.M.CARB 0.1W	5%	4K7Ω		
R1183	ERJ6GEYJ472	S.M.CARB 0.1W	5%	4K7Ω		
R1184	ERJ6GEYJ472	S.M.CARB 0.1W	5%	4K7Ω		
R1185	ERJ6GEYJ101	S.M.CARB 0.1W	5%	100Ω		
R1186	ERJ6GEYJ103	S.M.CARB 0.1W	5%	10KΩ		
R1188	ERJ6GEYJ222	S.M.CARB 0.1W	5%	2K2Ω		
R1190	ERJ6GEYOR00	S.M.CARB 0.1W	5%	0Ω		
R1191	ERJ6GEYJ104	S.M.CARB 0.1W	5%	100KΩ		
R1192	ERJ6GEYJ104	S.M.CARB 0.1W	5%	100KΩ		
R1193	ERJ6GEYJ103	S.M.CARB 0.1W	5%	10KΩ		
R1194	ERJ6GEYJ101	S.M.CARB 0.1W	5%	100Ω		
R1301	ERJ6GEYOR00	S.M.CARB 0.1W	5%	0Ω		
R1302	ERJ6GEYJ392	S.M.CARB 0.1W	5%	3K9Ω		
R1305	ERJ6GEYJ560	S.M.CARB 0.1W	5%	56Ω		

Ref No.	Part No.	Description
R1306	ERJ6GEYJ101	S.M.CARB 0.1W 5% 100Ω
R1315	ERJ6GEYJ101	S.M.CARB 0.1W 5% 100Ω
R1317	ERJ6GEYJ181	S.M.CARB 0.1W 5% 180Ω
R1318	ERJ6GEYJ181	S.M.CARB 0.1W 5% 180Ω
R1319	ERJ6GEY0R00	S.M.CARB 0.1W 5% 0Ω
R1340	ERJ6GEYJ102	S.M.CARB 0.1W 5% 1KΩ
R1504	ERJ6GEYJ121	S.M.CARB 0.1W 5% 120Ω
R1507	ERJ6GEYJ272	S.M.CARB 0.1W 5% 2K7Ω
R1508	ERJ6GEYJ121	S.M.CARB 0.1W 5% 120Ω
R1510	ERJ6GEYJ101	S.M.CARB 0.1W 5% 100Ω
R1511	ERJ6GEYJ272	S.M.CARB 0.1W 5% 2K7Ω
R1513	ERJ6GEYJ272	S.M.CARB 0.1W 5% 2K7Ω
R1515	ERJ6GEYJ471	S.M.CARB 0.1W 5% 470Ω
R1516	ERJ6GEYJ471	S.M.CARB 0.1W 5% 470Ω
R1517	ERJ6GEYJ471	S.M.CARB 0.1W 5% 470Ω
R1518	ERJ6GEYJ471	S.M.CARB 0.1W 5% 470Ω
R1519	ERJ6GEYJ471	S.M.CARB 0.1W 5% 470Ω
R1520	ERJ6GEYJ471	S.M.CARB 0.1W 5% 470Ω
R1523	ERJ6GEYJ101	S.M.CARB 0.1W 5% 100Ω
R1550	ERJ6GEYJ221	S.M.CARB 0.1W 5% 220Ω
R1554	ERJ6GEYJ103	S.M.CARB 0.1W 5% 10KΩ
R1555	ERJ6GEYJ331	S.M.CARB 0.1W 5% 330Ω
R1556	ERJ6GEYJ103	S.M.CARB 0.1W 5% 10KΩ
R1557	ERJ6GEYJ680	S.M.CARB 0.1W 5% 68Ω
R1559	ERJ6GEYJ560	S.M.CARB 0.1W 5% 56Ω
R1560	ERJ6GEYJ101	S.M.CARB 0.1W 5% 100Ω
R1561	ERJ6GEYJ101	S.M.CARB 0.1W 5% 100Ω
R1562	ERJ6GEYJ101	S.M.CARB 0.1W 5% 100Ω
R1564	ERJ6GEYJ101	S.M.CARB 0.1W 5% 100Ω
R1565	ERJ6GEYJ562	S.M.CARB 0.1W 5% 5K6Ω
R1566	ERJ6GEYJ392	S.M.CARB 0.1W 5% 3K9Ω
R1567	ERJ6GEYJ103	S.M.CARB 0.1W 5% 10KΩ
R1568	ERJ6GEYJ221	S.M.CARB 0.1W 5% 220Ω
R1570	ERJ6GEYJ331	S.M.CARB 0.1W 5% 330Ω
R1572	ERJ6GEY0R00	S.M.CARB 0.1W 5% 0Ω
R1575	ERJ6GEYJ391	S.M.CARB 0.1W 5% 390Ω
R1576	ERJ6GEYJ821	S.M.CARB 0.1W 5% 820Ω
R1577	ERJ6GEYJ750	S.M.CARB 0.1W 5% 75Ω
R1578	ERJ6GEYJ100	S.M.CARB 0.1W 5% 10Ω
R1581	ERJ6GEYJ223	S.M.CARB 0.1W 5% 22KΩ
R1582	ERJ6GEYJ223	S.M.CARB 0.1W 5% 22KΩ
R1583	ERJ6GEYJ560	S.M.CARB 0.1W 5% 56Ω
R1584	ERJ6GEYJ101	S.M.CARB 0.1W 5% 100Ω
R1587	ERJ6GEYJ223	S.M.CARB 0.1W 5% 22KΩ
R1605	ERJ6GEYJ101	S.M.CARB 0.1W 5% 100Ω
R1606	ERJ6GEYJ101	S.M.CARB 0.1W 5% 100Ω
R1608	ERJ6GEYJ472	S.M.CARB 0.1W 5% 4K7Ω
R1620	ERJ6GEYJ472	S.M.CARB 0.1W 5% 4K7Ω
R1621	ERJ6GEYJ101	S.M.CARB 0.1W 5% 100Ω
R1622	ERJ6GEYJ101	S.M.CARB 0.1W 5% 100Ω
R1627	ERJ6GEYJ622	SM.CARB0.125W 5% 6.2KΩ
R1628	ERJ6GEYJ161	SM.CARB0.125W 5% 160Ω
R1629	ERJ6GEYJ201	S.M.CARB 0.1W 5% 200Ω
R1630	ERJ6GEYJ181	S.M.CARB 0.1W 5% 180Ω
R1631	ERJ6GEYJ103	S.M.CARB 0.1W 5% 10KΩ
R1632	ERJ6GEYJ133	SM.CARB0.125W 5% 13KΩ
R1633	ERJ6GEYJ151	S.M.CARB 0.1W 5% 150Ω
R1634	ERJ6GEYJ472	S.M.CARB 0.1W 5% 4K7Ω
R1635	ERJ6GEYJ472	S.M.CARB 0.1W 5% 4K7Ω
R1636	ERJ6GEYJ561	S.M.CARB 0.1W 5% 560Ω
R1637	ERJ6GEYJ471	S.M.CARB 0.1W 5% 470Ω
R1638	ERJ6GEYJ561	S.M.CARB 0.1W 5% 560Ω
R1639	ERJ6GEYJ471	S.M.CARB 0.1W 5% 470Ω
R1641	ERJ6GEYJ471	S.M.CARB 0.1W 5% 470Ω
R1643	ERJ6GEYJ102	S.M.CARB 0.1W 5% 1KΩ
R1644	ERJ6GEYJ471	S.M.CARB 0.1W 5% 470Ω
R1646	ERJ6GEYJ331	S.M.CARB 0.1W 5% 330Ω
R1647	ERJ6GEYJ151	S.M.CARB 0.1W 5% 150Ω
R1648	ERJ6GEYJ471	S.M.CARB 0.1W 5% 470Ω
R1649	ERJ6GEYJ560	S.M.CARB 0.1W 5% 56Ω
R1650	ERJ6GEYJ471	S.M.CARB 0.1W 5% 470Ω
R1652	ERJ6GEYJ561	S.M.CARB 0.1W 5% 560Ω
R1653	ERJ6GEYJ471	S.M.CARB 0.1W 5% 470Ω

Ref No.	Part No.	Description
R1654	ERJ6GEYJ560	S.M.CARB 0.1W 5% 56Ω
R1656	ERJ6GEYJ102	S.M.CARB 0.1W 5% 1KΩ
R1657	ERJ6GEYJ471	S.M.CARB 0.1W 5% 470Ω
R1658	ERJ6GEYJ561	S.M.CARB 0.1W 5% 560Ω
R1659	ERJ6GEYJ560	S.M.CARB 0.1W 5% 56Ω
R1662	ERJ6GEYJ560	S.M.CARB 0.1W 5% 56Ω
R1666	ERJ6GEY0R00	S.M.CARB 0.1W 5% 0Ω
R1667	ERJ6GEYJ560	S.M.CARB 0.1W 5% 56Ω
R1668	ERJ6GEYJ560	S.M.CARB 0.1W 5% 56Ω
R1669	ERJ6GEYJ272	S.M.CARB 0.1W 5% 2K7Ω
R1670	ERJ6GEYJ272	S.M.CARB 0.1W 5% 2K7Ω
R1671	ERJ6GEYJ272	S.M.CARB 0.1W 5% 2K7Ω
R1672	ERJ6GEYJ151	S.M.CARB 0.1W 5% 150Ω
R1673	ERJ6GEYJ151	S.M.CARB 0.1W 5% 150Ω
R1674	ERJ6GEYJ221	S.M.CARB 0.1W 5% 220Ω
R1679	ERJ6GEYJ473	S.M.CARB 0.1W 5% 47KΩ
R1680	ERJ6GEYJ153	S.M.CARB 0.1W 5% 15KΩ
R1681	ERJ6GEY0R00	S.M.CARB 0.1W 5% 0Ω
R1682	ERJ6GEYJ151	S.M.CARB 0.1W 5% 150Ω
R1683	ERJ6GEYJ151	S.M.CARB 0.1W 5% 150Ω
R1688	ERJ6GEYJ561	S.M.CARB 0.1W 5% 560Ω
R1701	ERJ6GEYJ472	S.M.CARB 0.1W 5% 4K7Ω
R1702	ERJ6GEYJ101	S.M.CARB 0.1W 5% 100Ω
R1703	ERJ6GEYJ101	S.M.CARB 0.1W 5% 100Ω
R2001	ERJ6GEYJ473	S.M.CARB 0.1W 5% 47KΩ
R2004	ERJ6GEYJ103	S.M.CARB 0.1W 5% 10KΩ
R2005	ERJ6GEYJ101	S.M.CARB 0.1W 5% 100Ω
R2006	ERJ6GEYJ101	S.M.CARB 0.1W 5% 100Ω
R2007	ERJ6GEYJ183	S.M.CARB 0.1W 5% 18KΩ
R2008	ERJ6GEY0R00	S.M.CARB 0.1W 5% 0Ω
R2009	ERJ6GEY0R00	S.M.CARB 0.1W 5% 0Ω
R2010	ERJ6GEYJ101	S.M.CARB 0.1W 5% 100Ω
R2011	ERJ6GEYJ222	S.M.CARB 0.1W 5% 2K2Ω
R2012	ERJ6GEYJ101	S.M.CARB 0.1W 5% 100Ω
R2013	ERJ6GEYJ222	S.M.CARB 0.1W 5% 2K2Ω
R2014	ERJ6GEYJ471	S.M.CARB 0.1W 5% 470Ω
R2015	ERJ6GEYJ222	S.M.CARB 0.1W 5% 2K2Ω
R2016	ERJ6GEYJ471	S.M.CARB 0.1W 5% 470Ω
R2017	ERJ6GEYJ222	S.M.CARB 0.1W 5% 2K2Ω
R2018	ERJ6GEYJ471	S.M.CARB 0.1W 5% 470Ω
R2019	ERJ6GEYJ471	S.M.CARB 0.1W 5% 470Ω
R2020	ERJ6GEYJ562	S.M.CARB 0.1W 5% 5K6Ω
R2021	ERJ6GEYJ102	S.M.CARB 0.1W 5% 1KΩ
R2022	ERJ6GEYJ471	S.M.CARB 0.1W 5% 470Ω
R2023	ERJ6GEY0R00	S.M.CARB 0.1W 5% 0Ω
R2025	ERJ6GEYJ123	S.M.CARB 0.1W 5% 12KΩ
R2026	ERJ6GEYJ562	S.M.CARB 0.1W 5% 5K6Ω
R2027	ERJ6GEYJ102	S.M.CARB 0.1W 5% 1KΩ
R2038	ERJ6GEY0R00	S.M.CARB 0.1W 5% 0Ω
R2039	ERJ6GEYJ471	S.M.CARB 0.1W 5% 470Ω
R2044	ERJ6GEYJ471	S.M.CARB 0.1W 5% 470Ω
R2045	ERJ6GEYJ471	S.M.CARB 0.1W 5% 470Ω
R2351	ERQ14AJW100	METAL 0.25W 5% 10Ω ▲
R2352	ERD25TJ101	CARBON 0.25W 5% 100Ω
R2353	ERD25TJ101	CARBON 0.25W 5% 100Ω
R2354	ERD25TJ473	CARBON 0.25W 5% 47KΩ
R2355	ERD25TJ102	CARBON 0.25W 5% 1KΩ
R2356	ERD25TJ102	CARBON 0.25W 5% 1KΩ
R2357	ERD25TJ102	CARBON 0.25W 5% 1KΩ
R2358	ERD25TJ102	CARBON 0.25W 5% 1KΩ
R2359	ERD25TJ271	CARBON 0.25W 5% 270Ω
R2360	ERD25TJ183	CARBON 0.25W 5% 18KΩ
R2361	ERD25TJ100	CARBON 0.25W 5% 10Ω
R2371	ERQ14AJW100	METAL 0.25W 5% 10Ω ▲
R2372	ERD25TJ101	CARBON 0.25W 5% 100Ω
R2373	ERD25TJ101	CARBON 0.25W 5% 100Ω
R2374	ERD25TJ473	CARBON 0.25W 5% 47KΩ
R2375	ERD25TJ102	CARBON 0.25W 5% 1KΩ
R2376	ERD25TJ102	CARBON 0.25W 5% 1KΩ
R2377	ERD25TJ102	CARBON 0.25W 5% 1KΩ
R2378	ERD25TJ102	CARBON 0.25W 5% 1KΩ
R2379	ERD25TJ271	CARBON 0.25W 5% 270Ω

Ref No.	Part No.	Description			
R2380	ERD25TJ183	CARBON 0.25W	5%	18KΩ	
R2381	ERD25TJ100	CARBON 0.25W	5%	10Ω	
R3006	ERJ6GEYJ750	S.M.CARB 0.1W	5%	75Ω	
R3101	ERJ6GEYJ102	S.M.CARB 0.1W	5%	1KΩ	
R3102	ERJ6GEYJ102	S.M.CARB 0.1W	5%	1KΩ	
R3107	ERJ6GEYJ104	S.M.CARB 0.1W	5%	100KΩ	
R3108	ERJ6GEYJ104	S.M.CARB 0.1W	5%	100KΩ	
R3109	ERJ6GEYJ681	S.M.CARB 0.1W	5%	680Ω	
R3110	ERJ6GEYJ681	S.M.CARB 0.1W	5%	680Ω	
R3114	ERJ6GEYJ681	S.M.CARB 0.1W	5%	680Ω	
R3115	ERJ6GEYJ104	S.M.CARB 0.1W	5%	100KΩ	
R3117	ERJ6GEYJ104	S.M.CARB 0.1W	5%	100KΩ	
R3118	ERJ6GEYJ681	S.M.CARB 0.1W	5%	680Ω	
R3126	ERJ6GEYJ102	S.M.CARB 0.1W	5%	1KΩ	
R3127	ERJ6GEYJ102	S.M.CARB 0.1W	5%	1KΩ	
R3128	ERJ6GEYJ104	S.M.CARB 0.1W	5%	100KΩ	
R3129	ERJ6GEYJ104	S.M.CARB 0.1W	5%	100KΩ	
R3130	ERJ6GEYJ681	S.M.CARB 0.1W	5%	680Ω	
R3131	ERJ6GEYJ681	S.M.CARB 0.1W	5%	680Ω	
R3132	ERD2FCVG100T	CARBON 2W	2%	10Ω	
R3133	ERJ6GEYJ101	S.M.CARB 0.1W	5%	100Ω	
R3134	ERJ6GEYJ101	S.M.CARB 0.1W	5%	100Ω	
R3135	ERJ6GEYJ101	S.M.CARB 0.1W	5%	100Ω	
R3136	ERJ6GEYJ101	S.M.CARB 0.1W	5%	100Ω	
R3137	ERJ6GEYJ750	S.M.CARB 0.1W	5%	75Ω	
R3138	ERJ6GEYJ470	S.M.CARB 0.1W	5%	47Ω	
R3139	ERJ6GEYJ101	S.M.CARB 0.1W	5%	100Ω	
R3140	ERJ6GEYJ101	S.M.CARB 0.1W	5%	100Ω	
R3141	ERJ6GEYJ101	S.M.CARB 0.1W	5%	100Ω	
R3142	ERJ6GEYJ101	S.M.CARB 0.1W	5%	100Ω	
R3143	ERJ6GEYJ333	S.M.CARB 0.1W	5%	33KΩ	
R3144	ERJ6GEYJ101	S.M.CARB 0.1W	5%	100Ω	
R3145	ERJ6GEYJ101	S.M.CARB 0.1W	5%	100Ω	
R3146	ERJ6GEYJ333	S.M.CARB 0.1W	5%	33KΩ	
R3147	ERJ6GEYJ153	S.M.CARB 0.1W	5%	15KΩ	
R3148	ERJ6GEYJ750	S.M.CARB 0.1W	5%	75Ω	
R3149	ERJ6GEYJ750	S.M.CARB 0.1W	5%	75Ω	
R3150	ERJ6GEYJ470	S.M.CARB 0.1W	5%	47Ω	
R3151	ERJ6GEYJ750	S.M.CARB 0.1W	5%	75Ω	
R3152	ERJ6GEYJ101	S.M.CARB 0.1W	5%	100Ω	
R3153	ERJ6GEYJ101	S.M.CARB 0.1W	5%	100Ω	
R3154	ERD2FCVG100T	CARBON 2W	2%	10Ω	
R3158	ERJ6GEYJ470	S.M.CARB 0.1W	5%	47Ω	
R3159	ERJ6GEYJ681	S.M.CARB 0.1W	5%	680Ω	
R3160	ERJ6GEYJ563	S.M.CARB 0.1W	5%	56KΩ	
R3161	ERJ6GEYJ121	S.M.CARB 0.1W	5%	120Ω	
R3162	ERJ6GEYJ101	S.M.CARB 0.1W	5%	100Ω	
R3163	ERJ6GEYJ153	S.M.CARB 0.1W	5%	15KΩ	
R3165	ERJ6GEYJ103	S.M.CARB 0.1W	5%	10KΩ	
R3167	ERJ6GEYJ103	S.M.CARB 0.1W	5%	10KΩ	
R3178	ERJ6GEY0R00	S.M.CARB 0.1W	5%	0Ω	
R3180	ERJ6GEY0R00	S.M.CARB 0.1W	5%	0Ω	
R3182	ERJ6GEY0R00	S.M.CARB 0.1W	5%	0Ω	
R3184	ERJ6GEY0R00	S.M.CARB 0.1W	5%	0Ω	
R3185	ERJ6GEYJ333	S.M.CARB 0.1W	5%	33KΩ	
R3186	ERJ6GEYJ101	S.M.CARB 0.1W	5%	100Ω	
R3187	ERJ6GEYJ333	S.M.CARB 0.1W	5%	33KΩ	
R3188	ERJ6GEYJ101	S.M.CARB 0.1W	5%	100Ω	
R3192	ERJ6GEY0R00	S.M.CARB 0.1W	5%	0Ω	
R3193	ERJ6GEY0R00	S.M.CARB 0.1W	5%	0Ω	
R3194	ERJ6GEYJ750	S.M.CARB 0.1W	5%	75Ω	
R3195	ERJ6GEYJ750	S.M.CARB 0.1W	5%	75Ω	
R3196	ERJ6GEYJ470	S.M.CARB 0.1W	5%	47Ω	
R3197	ERD2FCVG100T	CARBON 2W	2%	10Ω	
R3198	ERJ6GEYJ470	S.M.CARB 0.1W	5%	47Ω	
R3199	ERJ6GEYJ470	S.M.CARB 0.1W	5%	47Ω	
R3200	ERJ6GEYJ104	S.M.CARB 0.1W	5%	100KΩ	
R3201	ERJ6GEYJ332	S.M.CARB 0.1W	5%	3K3Ω	
R3202	ERJ6GEYJ332	S.M.CARB 0.1W	5%	3K3Ω	
R3205	ERJ6GEYJ104	S.M.CARB 0.1W	5%	100KΩ	
R3206	ERJ6GEYJ104	S.M.CARB 0.1W	5%	100KΩ	
R3207	ERJ6GEYJ104	S.M.CARB 0.1W	5%	100KΩ	
R3208	ERJ6GEYJ101	S.M.CARB 0.1W	5%	100Ω	

Ref No.	Part No.	Description			
R3209	ERJ6GEYJ101	S.M.CARB 0.1W	5%	100Ω	
R3210	ERJ6GEYJ152	S.M.CARB 0.1W	5%	1K5Ω	
R3211	ERJ6GEYJ152	S.M.CARB 0.1W	5%	1K5Ω	
R3212	ERJ6GEYJ123	S.M.CARB 0.1W	5%	12KΩ	
R3213	ERJ6GEYJ101	S.M.CARB 0.1W	5%	100Ω	
R3214	ERJ6GEYJ153	S.M.CARB 0.1W	5%	15KΩ	
R3215	ERD2FCVG100T	CARBON 2W	2%	10Ω	
R3216	ERJ6GEYJ680	S.M.CARB 0.1W	5%	68Ω	
R3217	ERJ6GEYJ102	S.M.CARB 0.1W	5%	1KΩ	
R3218	ERJ6GEYJ750	S.M.CARB 0.1W	5%	75Ω	
R3226	ERJ6GEYJ153	S.M.CARB 0.1W	5%	15KΩ	
R3227	ERJ6GEY0R00	S.M.CARB 0.1W	5%	0Ω	
R3228	ERJ6GEYJ680	S.M.CARB 0.1W	5%	68Ω	
R3229	ERJ6GEYJ101	S.M.CARB 0.1W	5%	100Ω	
R3230	ERJ6GEYJ102	S.M.CARB 0.1W	5%	1KΩ	
R3231	ERD2FCVG100T	CARBON 2W	2%	10Ω	
R3232	ERJ6GEYJ272	S.M.CARB 0.1W	5%	2K7Ω	
R3233	ERJ6GEYJ331	S.M.CARB 0.1W	5%	330Ω	
R3236	ERJ6GEYJ103	S.M.CARB 0.1W	5%	10KΩ	
R3237	ERJ6GEYJ103	S.M.CARB 0.1W	5%	10KΩ	
R3238	ERJ6GEYJ153	S.M.CARB 0.1W	5%	15KΩ	
R3239	ERJ6GEYJ153	S.M.CARB 0.1W	5%	15KΩ	
R3240	ERJ6GEYJ104	S.M.CARB 0.1W	5%	100KΩ	
R3351	ERJ6GEYJ101	S.M.CARB 0.1W	5%	100Ω	
R3352	ERJ6GEYJ472	S.M.CARB 0.1W	5%	4K7Ω	
R3353	ERJ6GEYJ474	S.M.CARB 0.1W	5%	470KΩ	
R3354	ERJ6GEYJ102	S.M.CARB 0.1W	5%	1KΩ	
R3355	ERJ6GEYJ391	S.M.CARB 0.1W	5%	390Ω	
R3501	ERJ6GEYJ100	S.M.CARB 0.1W	5%	10Ω	
R3502	ERJ6GEY0R00	S.M.CARB 0.1W	5%	0Ω	
R3503	ERJ6GEYJ471	S.M.CARB 0.1W	5%	470Ω	
R3505	ERJ6GEYJ100	S.M.CARB 0.1W	5%	10Ω	
R3506	ERJ6GEYJ100	S.M.CARB 0.1W	5%	10Ω	
R3507	ERJ6GEYJ472	S.M.CARB 0.1W	5%	4K7Ω	
R3508	ERJ6GEYJ151	S.M.CARB 0.1W	5%	150Ω	
R3509	ERJ6GEYJ102	S.M.CARB 0.1W	5%	1KΩ	
R3513	ERJ6GEYJ471	S.M.CARB 0.1W	5%	470Ω	
R3514	ERJ6GEYJ471	S.M.CARB 0.1W	5%	470Ω	
R3515	ERJ6GEYJ471	S.M.CARB 0.1W	5%	470Ω	
R3516	ERJ6GEYJ472	S.M.CARB 0.1W	5%	4K7Ω	
R3517	ERJ6GEYJ102	S.M.CARB 0.1W	5%	1KΩ	
R3518	ERJ6GEY0R00	S.M.CARB 0.1W	5%	0Ω	
R3520	ERJ6GEYJ221	S.M.CARB 0.1W	5%	220Ω	
R3521	ERJ6GEY0R00	S.M.CARB 0.1W	5%	0Ω	
R3522	ERJ6GEY0R00	S.M.CARB 0.1W	5%	0Ω	
R3523	ERJ6GEY0R00	S.M.CARB 0.1W	5%	0Ω	
R3526	ERD25TC0T	CARBON 0.25W	5%	0Ω	
R3531	ERJ6GEYJ221	S.M.CARB 0.1W	5%	220Ω	
R3532	ERJ6GEYJ391	S.M.CARB 0.1W	5%	390Ω	
R3534	ERD25TJ181	CARBON 0.25W	5%	180Ω	
R3536	ERJ6GEY0R00	S.M.CARB 0.1W	5%	0Ω	
R3539	ERJ6GEY0R00	S.M.CARB 0.1W	5%	0Ω	
R3540	ERJ6GEYJ392	S.M.CARB 0.1W	5%	3K9Ω	
R3541	ERJ6GEYJ392	S.M.CARB 0.1W	5%	3K9Ω	
R3542	ERJ6GEYJ392	S.M.CARB 0.1W	5%	3K9Ω	
R3802	ERG3FJ100	METAL 3W	5%	10Ω	△
R3803	ERJ6GEYJ221	S.M.CARB 0.1W	5%	220Ω	
R3804	ERJ6GEYJ101	S.M.CARB 0.1W	5%	100Ω	

SWITCHES

S801	ESB91232A	SWITCH	△
S1051	EVQ23405R	SWITCH	
S1052	EVQ23405R	SWITCH	
S1053	EVQ23405R	SWITCH	
S1054	EVQ23405R	SWITCH	
S1055	EVQ23405R	SWITCH	

TRANSFORMERS

T501	TLHA003	TRANSFORMER	
T551	ZTFH65013A	F.B.T.	
T801	ETP35KAN615U	TRANSFORMER	

Ref No.	Part No.	Description
T802	ETS49AH137ND	TRANSFORMER
T803	ETQ19K55AY	TRANSFORMER
FILTERS		
X101	EFCT6504BF	FILTER
X102	EFCT5M7MW3	FILTER
X103	EFCT6R0MW5	FILTER
X104	K3953-M100	SAW FILTER
X105	K9456M	SAW FILTER

Ref No.	Part No.	Description
X106	EFCV3195T6	CERAMIC FILTER
X107	EFCT7004BF	CERAMIC FILTER
X109	EFCV4045T4	CERAMIC FILTER
X601	TSSA024	CRYSTAL
X602	TSSA025	CRYSTAL
X1101	TAF10020	CRYSTAL
X1551	TSSA009	CRYSTAL
X2001	4730007158	CRYSTAL
X3501	TSSA009	CRYSTAL

NOTE:

For models with the dark walnut finish please refer to the TX-28XD60C/A and TX-25XD60C/A Difference Lists and for Models with the light mahogany please refer to the TX-28XD60C/B AND TX-25XD60C/B

DIFFERENCES FOR TX-25XD60C

Ref No.	Part No.	Description
MISCELLANEOUS COMPONENTS		
4)	TNPA0292AP	Y-PC.B. ▲
5)	TLK8E05120	DEGAUSS COIL ▲
7)	A59ECF50X71	CRT ▲
8)	TKY8E151-2	CABINET ▲
9)	TKP8E1168	SPEAKER NET
10)	TBX8E040	POWER BUTTON BLACK
11)	TKP8E1173	LEFT PANEL (BLACK)
12)	TKP8E1171	TOP PANEL BLACK
14)	TQF8E2526	MODEL LABEL
15)	TKU8E00310	BACK COVER ▲
16)	TNPA0295AS	D P.C.B. ▲
20)	TNPH0063BL	E P.C.B. ▲
26)	TKP8E1201	RIGHT PANEL BLACK
	TPC8E4613	OUTER CARTON
	TPD8E631	TOP CUSHION
	TPD8E632	BOTTOM CUSHION
INTEGRATED CIRCUITS		
IC1104	X24C0301BM	EAROM
IC1105	27C2001-503	EPROM
IC603	TDA4780/V4	RGB VIDEO PROCESSOR
RESISTOR		
R558	ERD25TJ823	CARBON 0.25W 5% 82KΩ

DIFFERENCES FOR TX-28XD60C

Ref No.	Part No.	Description
MISCELLANEOUS COMPONENTS		
4)	TNPA0292AF	Y PC.B. ▲
5)	TLK8E05125	DEGAUSS COIL ▲
7)	A66ECF61X71	CRT ▲
8)	TKY8E161	CABINET ▲
9)	TKP8E1169	SPEAKER NET
10)	TBX8E040	POWER BUTTON BLACK
11)	TKP8E1175	LEFT PANEL (BLACK)
12)	TKP8E1172	TOP PANEL (BLACK)
14)	TQF8E2529	MODEL LABEL
15)	TKU8E00320	BACK COVER ▲
16)	TNPA0295AR	D P.C.B. ▲
20)	TNPH0063BH	E P.C.B. ▲
26)	TKP8E1199	RIGHT PANEL (BLACK)
	TPC8E4587	OUTER CARTON
	TPD8E633	TOP CUSHION
	TPD8E634	BOTTOM CUSHION
INTEGRATED CIRCUITS		
IC1104	X24C0302BN	EAROM
IC1105	27C2001501AC	EPROM
IC603	TDA4780	RGB VIDEO PROCESSOR
RESISTOR		
R558	ERO50PKF4532	METAL 50W 1% 45KΩ ▲

DIFFERENCES FOR TX-25XD60C/A

Ref No.	Part No.	Description
MISCELLANEOUS COMPONENTS		
4)	TNPA0292AP	Y-PC.B. ▲
5)	TLK8E05120	DEGAUSS COIL ▲
7)	A59ECF50X71	CRT ▲
8)	TKY8E151-2	CABINET ▲
9)	TKP8E1168	SPEAKER NET
10)	TBX8E045	POWER BUTTON (DARK WOOD)
11)	TKP8E1192	LEFT PANEL (DARK WOOD)
12)	TKP8E1190	TOP PANEL (DARK WOOD)
14)	TQF8E2527	MODEL LABEL
15)	TKU8E00310	BACK COVER ▲
16)	TNPA0295AS	D P.C.B. ▲
20)	TNPH0063BL	E P.C.B. ▲
26)	TKP8E1202	RIGHT PANEL (DARK WOOD)
27)	TKP8E1173	DOOR LID (DARK WOOD)
	TPC8E4613	OUTER CARTON
	TPD8E631	TOP CUSHION
	TPD8E632	BOTTOM CUSHION
INTEGRATED CIRCUITS		
IC1104	X24C0301BM	EAROM
IC1105	27C2001-503	EPROM
IC603	TDA4780/V4	RGB VIDEO PROCESSOR
RESISTOR		
R558	ERD25TJ823	CARBON 0.25W 5% 82KΩ

DIFFERENCES FOR TX-28XD60C/A

Ref No.	Part No.	Description
MISCELLANEOUS COMPONENTS		
4)	TNPA0292AF	Y PC.B. ▲
5)	TLK8E05125	DEGAUSS COIL ▲
7)	A66ECF61X71	CRT ▲
8)	TKY8E161	CABINET ▲
9)	TKP8E1169	SPEAKER NET
10)	TBX8E040	POWER BUTTON (DARK WOOD)
11)	TKP8E1184	LEFT PANEL (DARK WOOD)
12)	TKP8E1182	TOP PANEL (DARK WOOD)
14)	TQF8E2530	MODEL LABEL
15)	TKU8E00320	BACK COVER ▲
16)	TNPA0295AR	D P.C.B. ▲
20)	TNPH0063BH	E P.C.B. ▲
26)	TKP8E1203	RIGHT PANEL (DARK WOOD)
27)	TKP8E1180	DOOR LID (DARK WOOD)
	TPC8E4587	OUTER CARTON
	TPD8E633	TOP CUSHION
	TPD8E634	BOTTOM CUSHION
INTEGRATED CIRCUITS		
IC1104	X24C0302BN	EAROM
IC1105	27C2001501AC	EPROM
IC603	TDA4780	RGB VIDEO PROCESSOR
RESISTOR		
R558	ERO50PKF4532	METAL 50W 1% 45KΩ ▲

DIFFERENCES FOR TX-25XD60C/B

Ref No.	Part No.	Description	
MISCELLANEOUS COMPONENTS			
4)	TNPA0292AP	Y-P.C.B.	△
5)	TLK8E05120	DEGAUSS COIL	△
7)	A59ECF50X71	CRT	
8)	TKY8E151-2	CABINET	△
9)	TKP8E1168	SPEAKER NET	
10)	TBX8E046	POWER BUTTON (LIGHT WOOD)	
11)	TKP8E1193	LEFT PANEL (LIGHT WOOD)	
12)	TKP8E1191	TOP PANEL (LIGHT WOOD)	
14)	TQF8E2528	MODEL LABEL	
15)	TKU8E00310	BACK COVER	△
16)	TNPA0295AS	D P.C.B.	△
20)	TNPH0063BL	E P.C.B.	△
26)	TKP8E1196	RIGHT PANEL (LIGHT WOOD)	
27)	TKP8E1181	DOOR LID (LIGHT WOOD)	
	TPC8E4613	OUTER CARTON	
	TPD8E631	TOP CUSHION	
	TPD8E632	BOTTOM CUSHION	
INTEGRATED CIRCUITS			
IC1104	X24C0301BM	EAROM	
IC1105	27C2001-503	EPROM	
IC603	TDA4780/V4	RGB VIDEO PROCESSOR	
RESISTOR			
R558	ERD25TJ823	CARBON 0.25W 5% 82KΩ	

DIFFERENCES FOR TX-28XD60C/B







Ref No.	Part No.	Description	
MISCELLANEOUS COMPONENTS			
4)	TNPA0292AF	Y P.C.B.	△
5)	TLK8E05125	DEGAUSS COIL	△
7)	A66ECF61X71	CRT	△
8)	TKY8E161	CABINET	△
9)	TKP8E1169	SPEAKER NET	
10)	TBX8E046	POWER BUTTON (LIGHT WOOD)	
11)	TKP8E1185	LEFT PANEL (LIGHT WOOD)	
12)	TKP8E1183	TOP PANEL (LIGHT WOOD)	
14)	TQF8E2531	MODEL LABEL	
15)	TKU8E00320	BACK COVER	△
16)	TNPA0295AR	D P.C.B.	△
20)	TNPH0063BH	E P.C.B.	△
26)	TKP8E1188	RIGHT PANEL (LIGHT WOOD)	
27)	TKP8E1181	DOOR LID (LIGHT WOOD)	
	TPC8E4587	OUTER CARTON	
	TPD8E633	TOP CUSHION	
	TPD8E634	BOTTOM CUSHION	
INTEGRATED CIRCUITS			
IC1104	X24C0302BN	EAROM	
IC1105	27C2001501AC	EPROM	
IC603	TDA4780	RGB VIDEO PROCESSOR	
RESISTOR			
R558	ERO50PKF4532	METAL 50W 1% 45KΩ	△

SCHEMATIC DIAGRAM FOR MODELS TX-28XD60C TX-25XD60C (Euro-3H Chassis)

IMPORTANT SAFETY NOTICE

Components identified by  mark have special characteristics important for safety. When replacing any of these components, use only manufacturer's specified parts.

Notes

- RESISTOR**
All resistors are carbon 1/4W resistor, unless marked as follows:
Unit of resistance is OHM (Ω) (K=1,000, M=1,000,000).
- CAPACITORS**
All capacitors are ceramic 50V, unless marked as follows:
Unit of capacitance is μ F, unless otherwise stated.
- COIL**
Unit of inductance is μ H, unless otherwise stated.
- Components marked 'L' on the schematic diagram shows leadless parts.
- TEST POINT**
 : Test Point position
- EARTH SYMBOL**
 : Chassis Earth (Cold)  : Line Earth (Hot)
- VOLTAGE MEASUREMENT**
Voltage is measured by a DC voltmeter.
Measurement conditions are as follows:
Power source AC 220V-240V, 50Hz
Receiving Signal Colour Bar signal (RF)
All customer controls Maximum position
-  : Indicates the Video signal path
 : Indicates the Audio signal path
 : Indicates the Vertical/Horizontal signal path
- This schematic diagram is the latest at the time of printing and is subject to change without notice.

Remarks

- The Power Circuit contains a circuit area which uses a separate power supply to isolate the earth connection. The circuit is defined by HOT and COLD indications in the schematic diagram. All circuits, except the Power Circuit, are COLD. Take the following precautions:

Precautions







- Do not touch the hot part, or the hot and cold parts at the same time, as you are liable to a shock hazard.
- Do not short-circuit the hot and cold circuits as electrical components may be damaged.
- Do not connect an instrument, such as an oscilloscope, to the hot and cold circuits simultaneously, as this may cause fuse failure. Connect the earth of the instruments to the earth connection of the circuit being measured.
- Make sure to disconnect the power plug before removing the chassis.

ZEICHENERKLÄRUNG FÜR MODELL TX-28XD60C TX-25XD60C (Euro-3H Chassis)

WICHTIGER SICHERHEITSHINWEIS

Teile, die mit einem Hinweis  gekennzeichnet sind, sind wichtig für die Sicherheit. Sollte ein Auswechseln erforderlich sein, sind unbedingt Originalteile einzusetzen.

Anmerkung

- WIDERSTÄNDE**
Alle 1/4Watt Widerstände sind Kohlewiderstände, Abweichungen sind folgt gekennzeichnet.
Die Maßeinheit ist OHM (Ω) (K=1,000 M=1,000,000)
- KONDENSATOREN**
Alle Kondensatoren sind Keramikausführungen
Spannungsfestigkeit 50V. Abweichungen sind wie folgt gekennzeichnet.
Die Maßeinheit ist μ F, wenn keine anderen Bezeichnungen genannt sind
- SPULEN**
Die Maßeinheit ist μ H, Abweichungen sind gekennzeichnet.
Mit 'L' gekennzeichnete Teile sind ohne Anschlußdrähte.
- TESTPUNKTE**
 : Kennzeichnung der Testpunktpositio
- MASSE SYMBOL**
 : Erdung am Chassis  : Erdung an Masse-Leitung
- SPANNUNGSMESSUNG**
Spannungsmessungen sind mit einem DC-Voltmeter durchzuführen. Die Meßbedingungen sind folgende:
Netzspannung AC 220V-240V 50Hz
Wiedergabe Signal Farbbalken-Testbild
Alle übrigen Einstellungen für Benutzer Sollangaben
-  : Videosignalweg
 : Audiosignalweg
 : Signalweg für Hor/Vert. Synchronsignale
- Änderungen im Laufe der Fertigung sind möglich.

Bemerkungen

- Das Schaltnetzteil enthält Bereiche, die direkt mit dem Netz verbunden sind. Diese Bereiche sind im Schalplan mit HOT gekennzeichnet. Alle anderen Schaltungen sind mit COLD gekennzeichnet und haben keine direkte Verbindung mit dem Netz.

Für den netzverbundenen Bereich (HOT) sind folgende Vorsichtsmaßnahmen zu beachten:

- Weder die Leitungen im heißen noch Leitungen im kalten und im kalten Bereich gleichzeitig berühren. Es besteht die Gefahr eines elektrischen Schlages.
- Keinesfalls die Leitungen im heißen Bereich mit denen im kalten Bereich verbinden oder kurzschließen. Dies kann zur Zerstörung von Bauteilen oder Sicherungen führen. Außerdem ist die elektrische Betriebssicherheit des Gerätes nicht mehr gegeben.
- Keine Messinstrumente gleichzeitig an Leitungen im heißen und kalten Bereich anschließen. Sicherungen könnten zerstört werden. Die Erde des Messinstrumentes immer mit der des zu prüfenden Schaltkreises verbinden.
- Vor Ausbau des Chassis, Stecker aus der Netzsteckdose ziehen.

B BOARD
TNPA0317

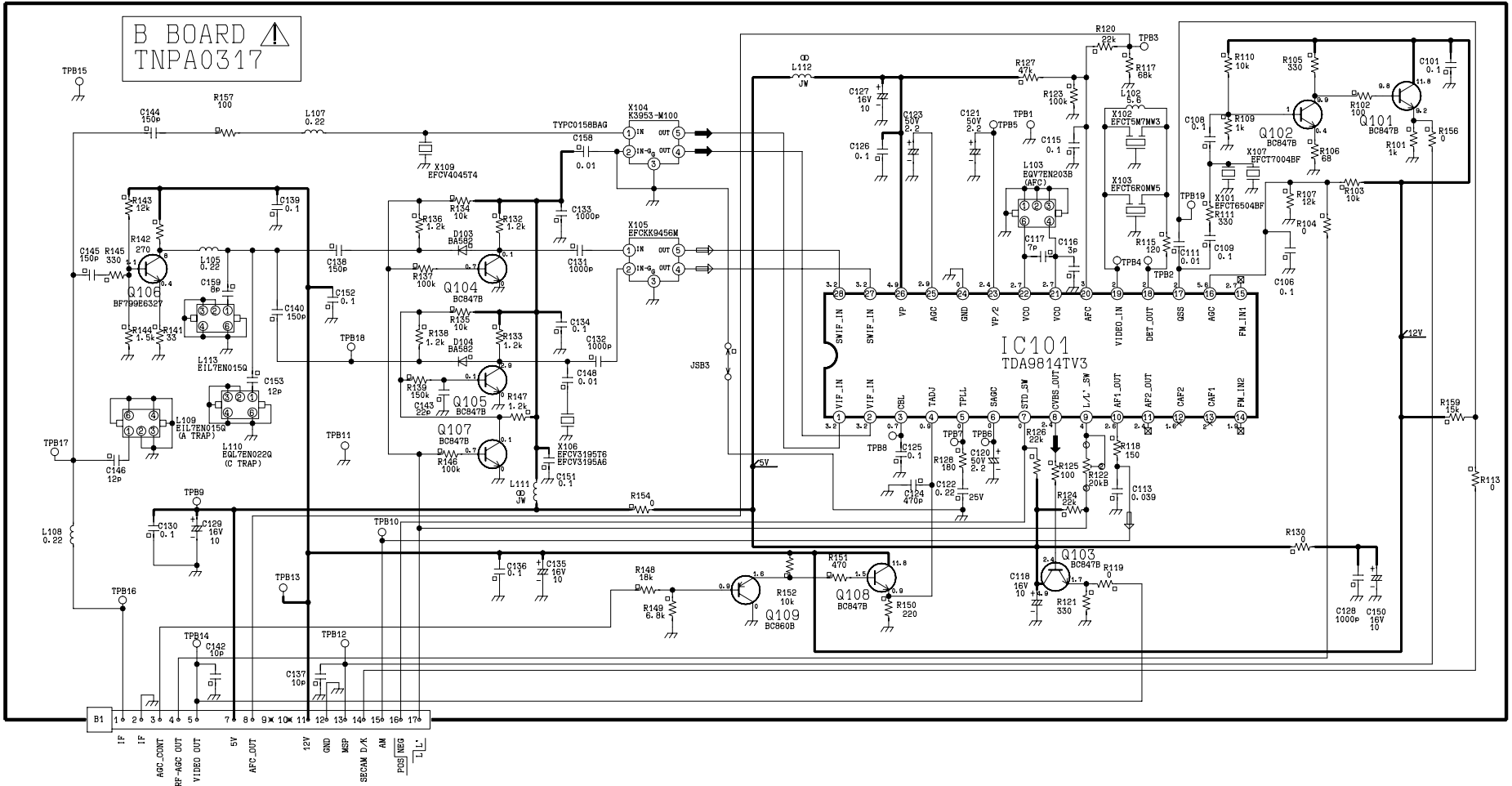

- 1 IF
- 2 IF
- 3 ARC_OUT
- 4 RF-ARC_OUT
- 5 VIDEO_OUT
- 6 5V
- 7 AFC_OUT
- 8 12V
- 9 GND
- 10 MSP
- 11 SECAM_D/K
- 12 PGM/NEG
- 13 L
- 14
- 15
- 16
- 17

D BOARD
TNPA0295

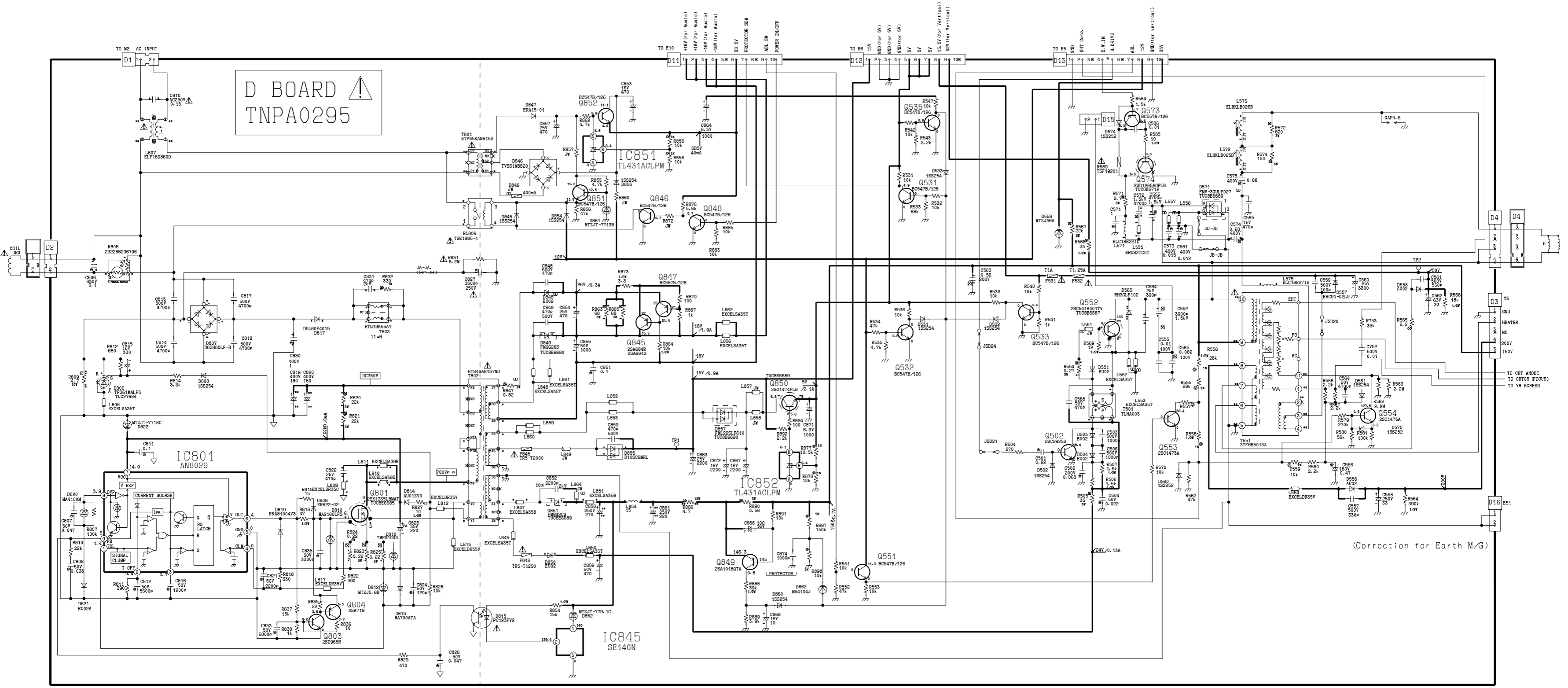

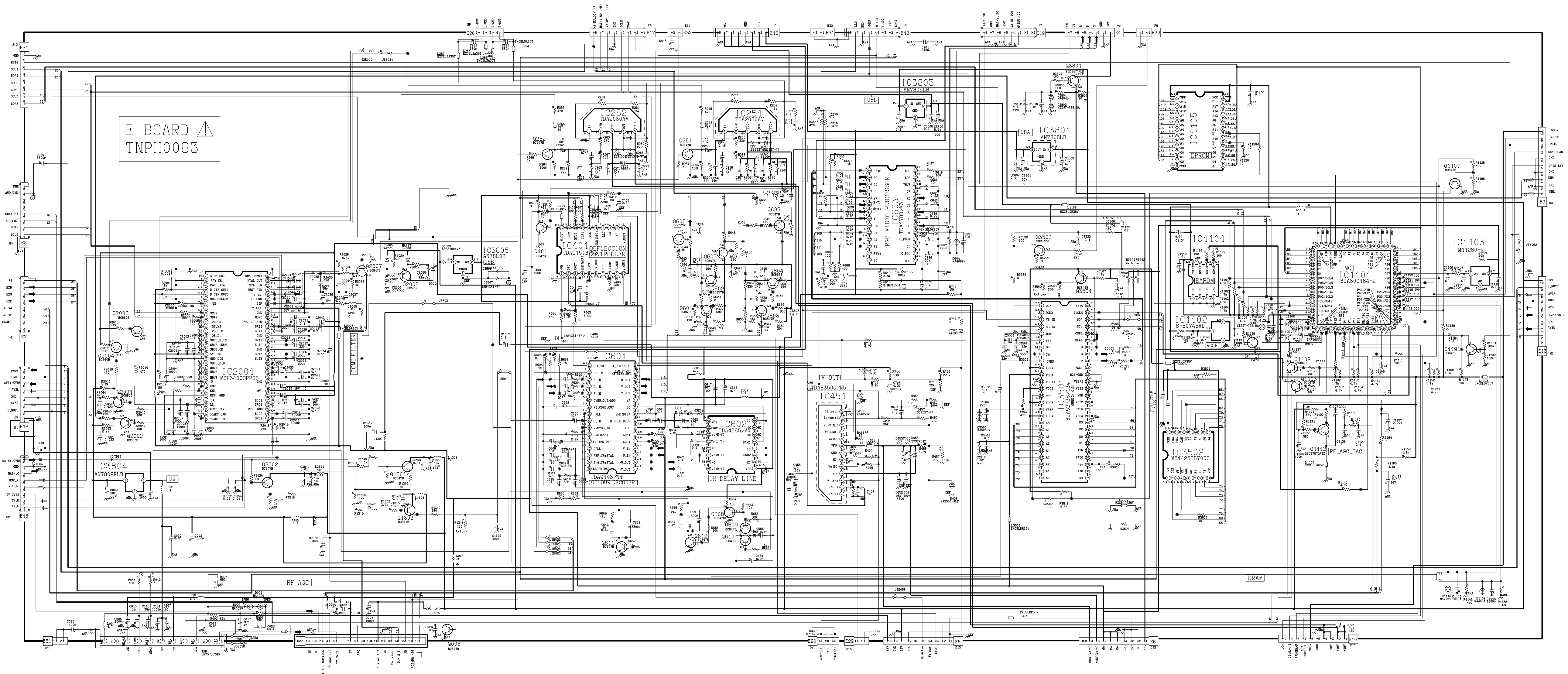

E BOARD
TNP0063

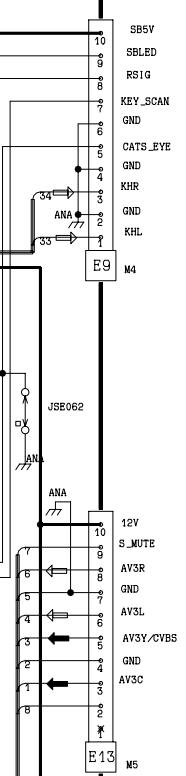

Back Cover

F BOARD
TNPA0756

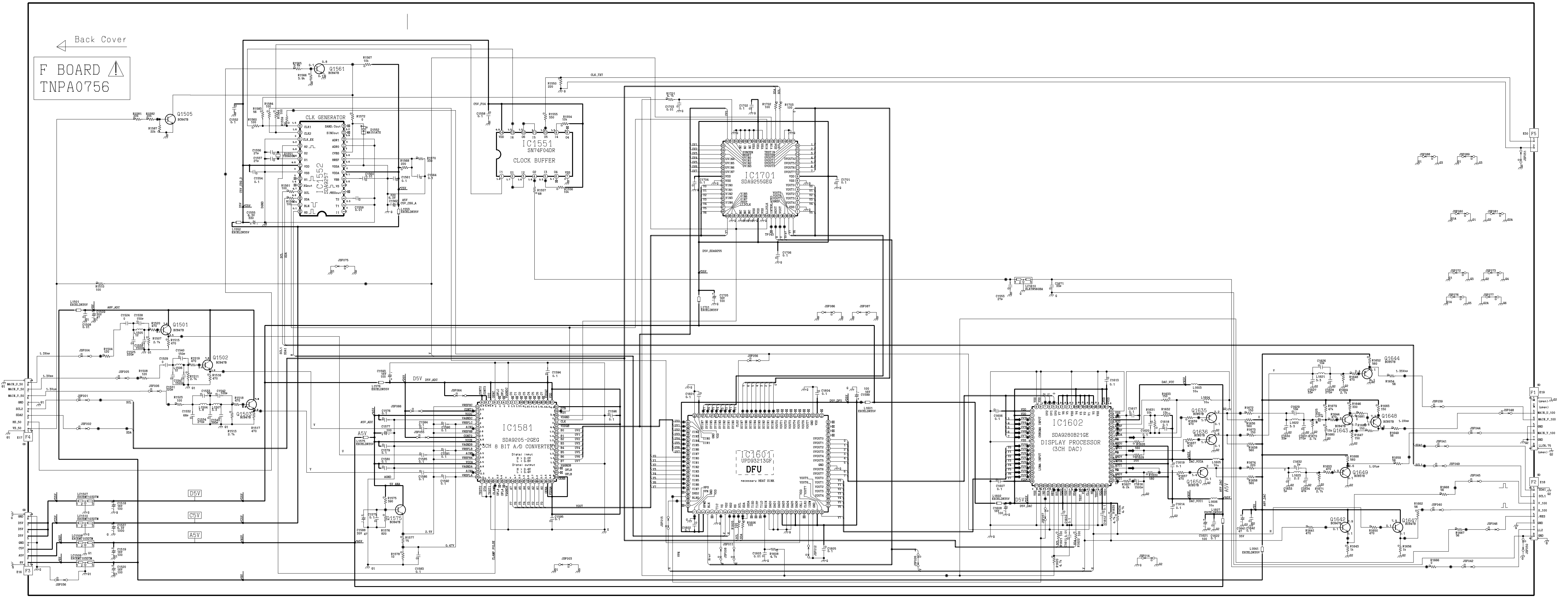

H BOARD
TNPA0293

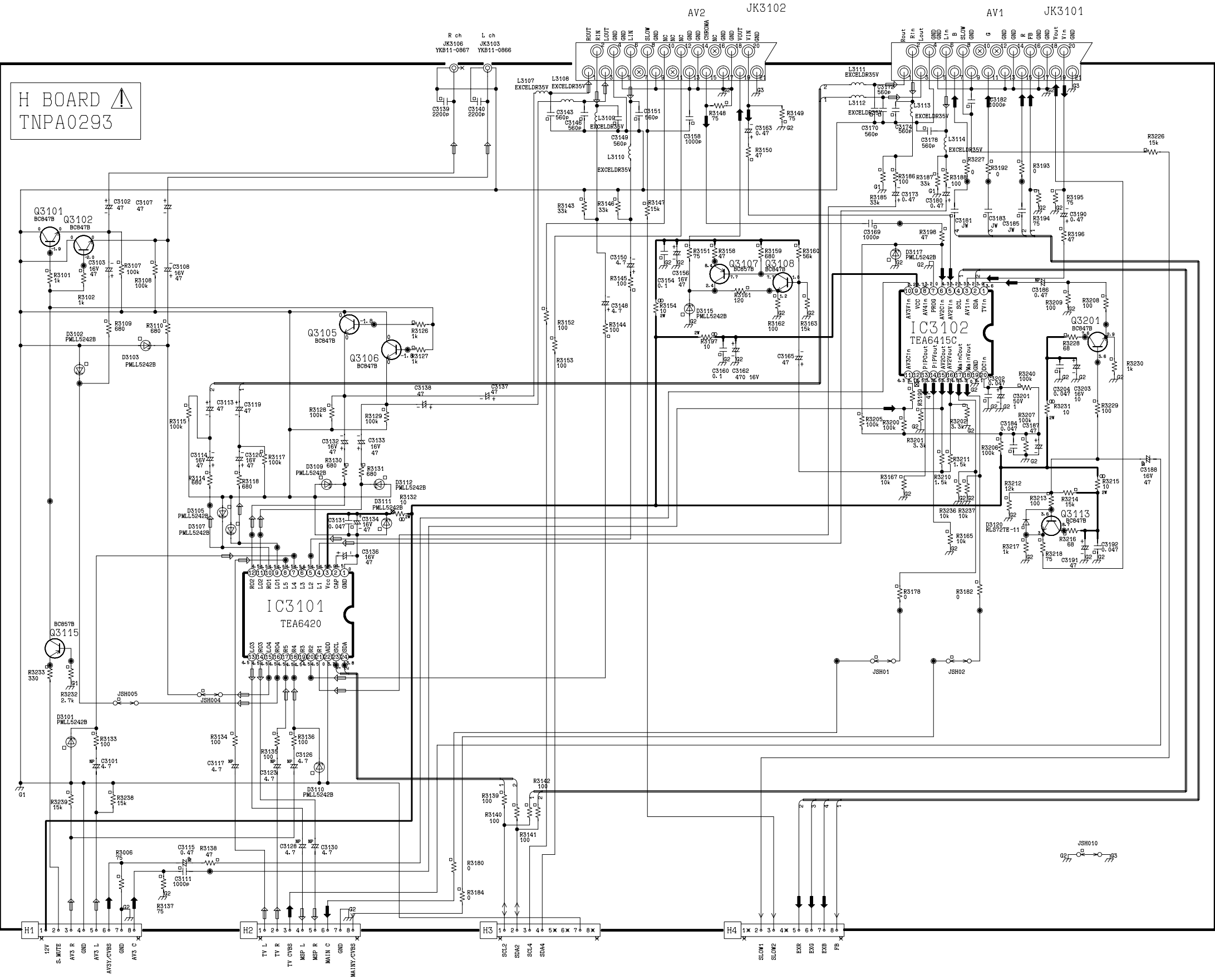

R ch L ch
JK3106 JK3103
YKB11-0867 YKB11-0866

AV2 JK3102 AV1 JK3101

H1 12V S.WITE AV3 R GND AV3 L AV3/CVBS GND AV3 C H2 TV L TV R TV CVBS MSP L MSP R MAIN C GND MAIN/CVBS H3 SCL2 SDA2 SCL4 SDA4 H4 SLOW1 SLOW2 EXR EXG EXB FB

M BOARD
TNPA0766

COLD

HOT

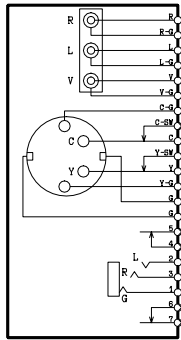
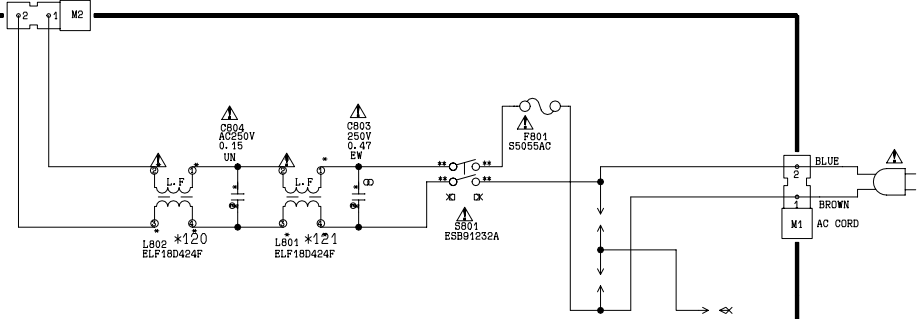

JK3001
TJBA039

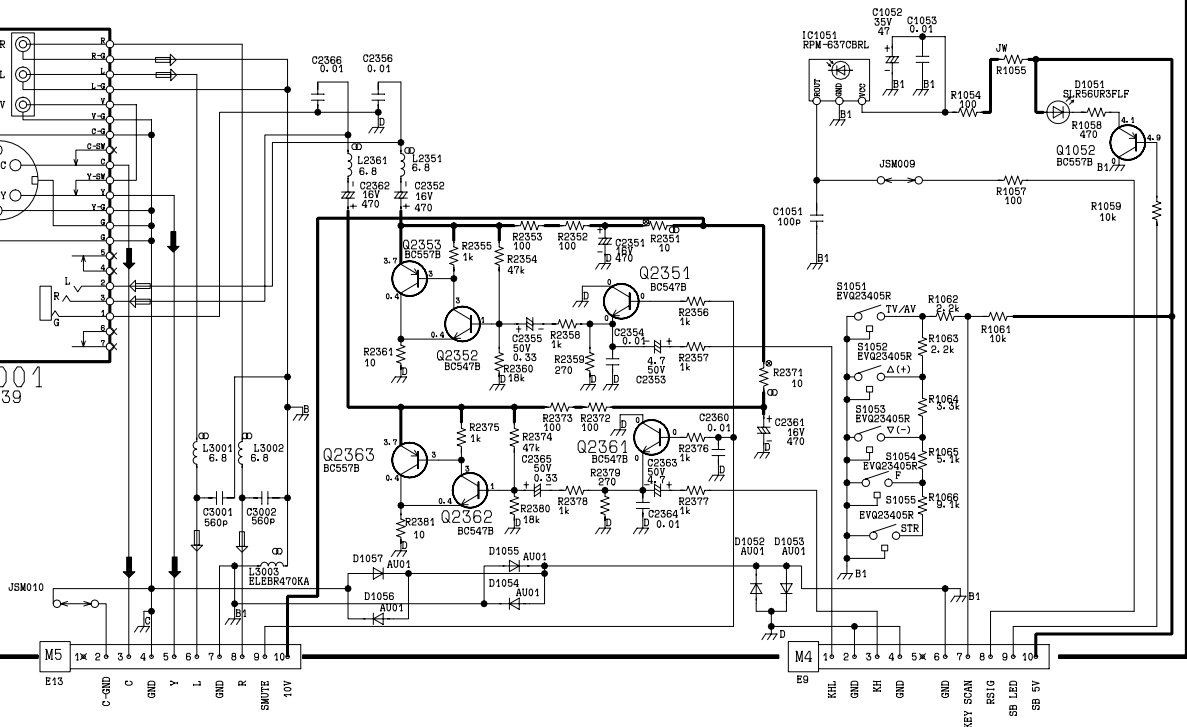

Y BOARD
TNPA0292

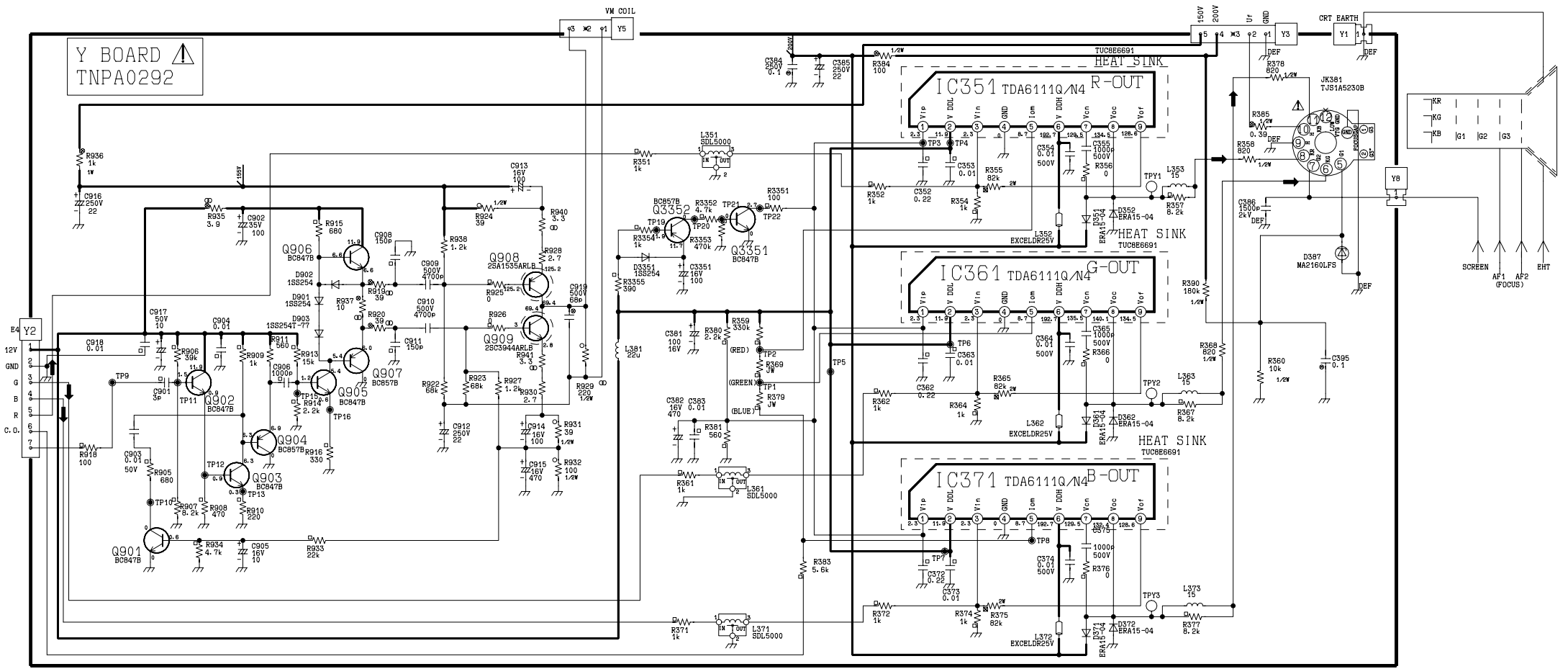

TNP A0317 (B2)

SEE REVERSE FOR ORDER NO.

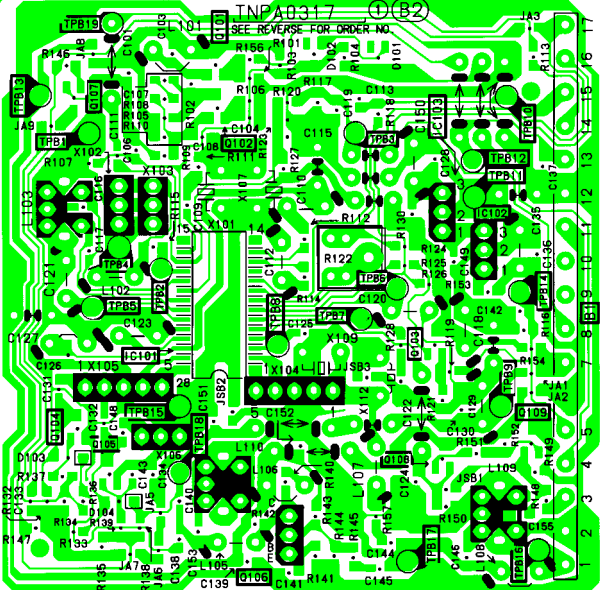

16
15
14
13
12
11
10
9
8
7
6
5
4
3
2

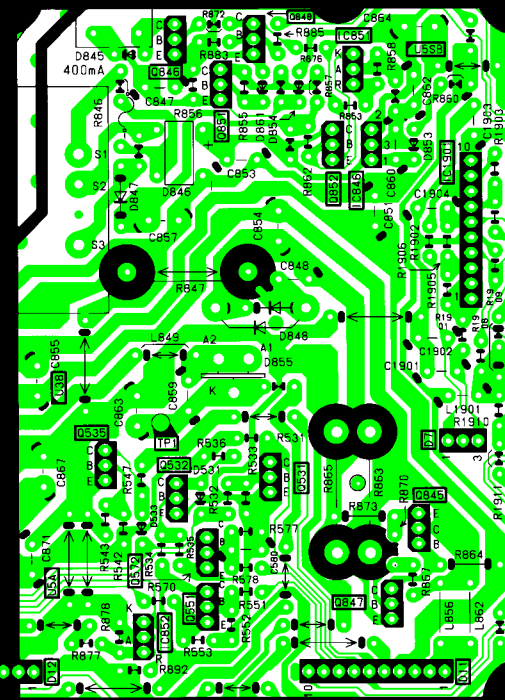
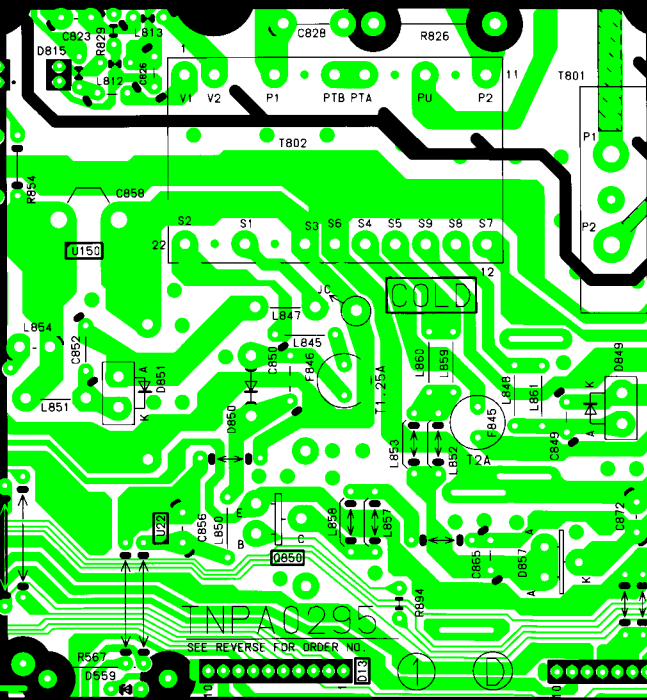
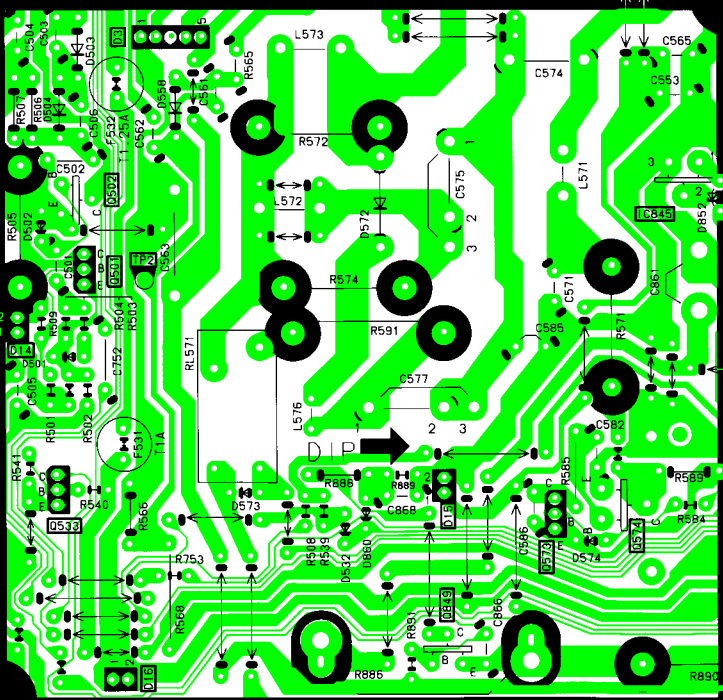
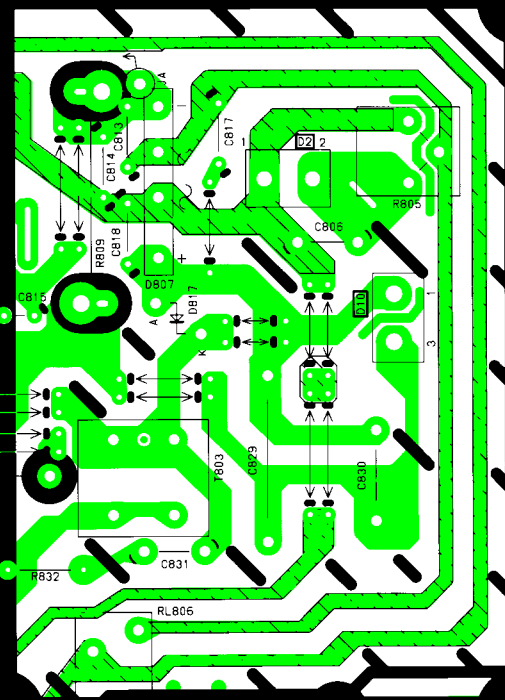
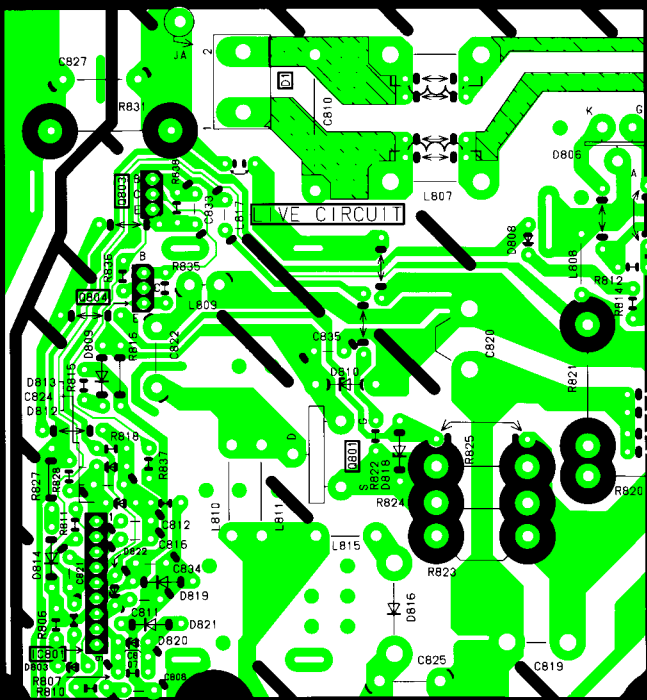
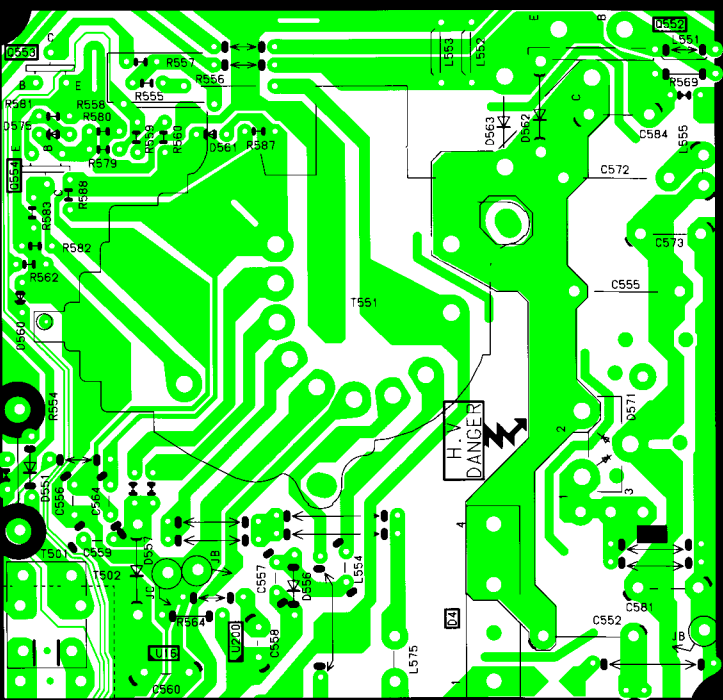

SEE REVERSE FOR ORDER NO.

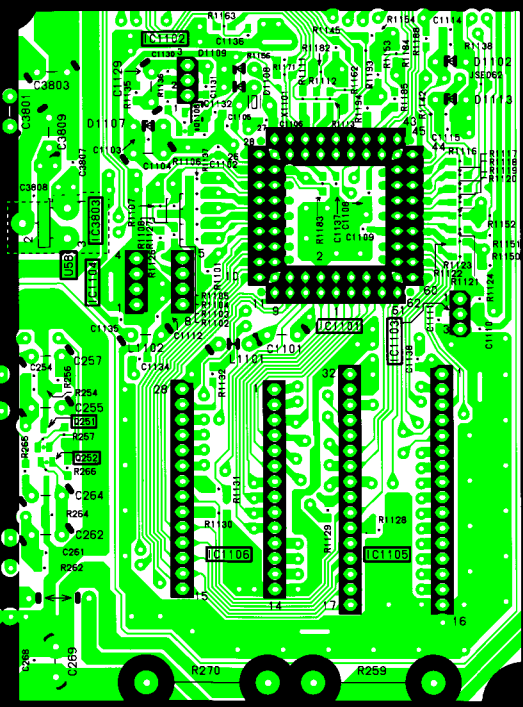
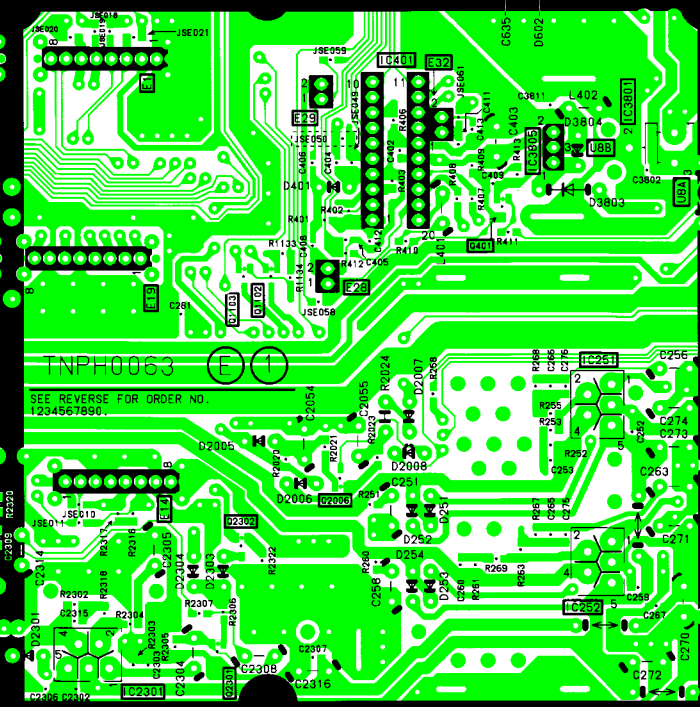
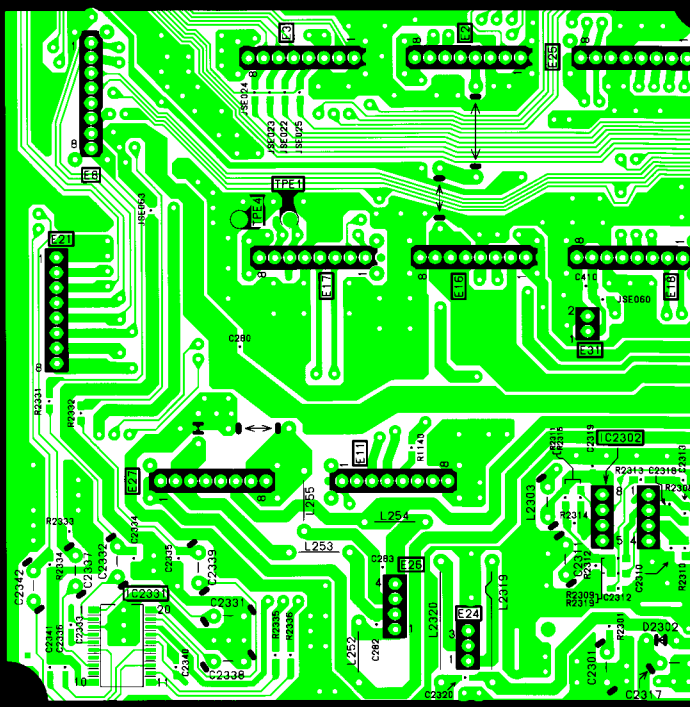
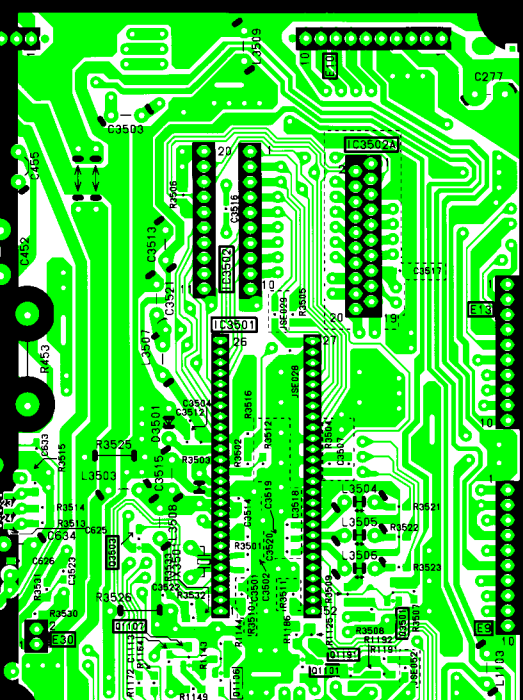
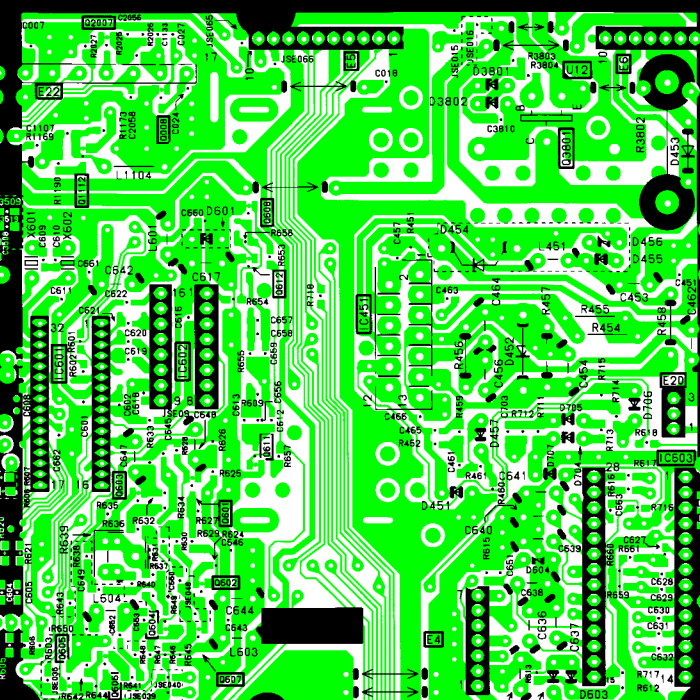
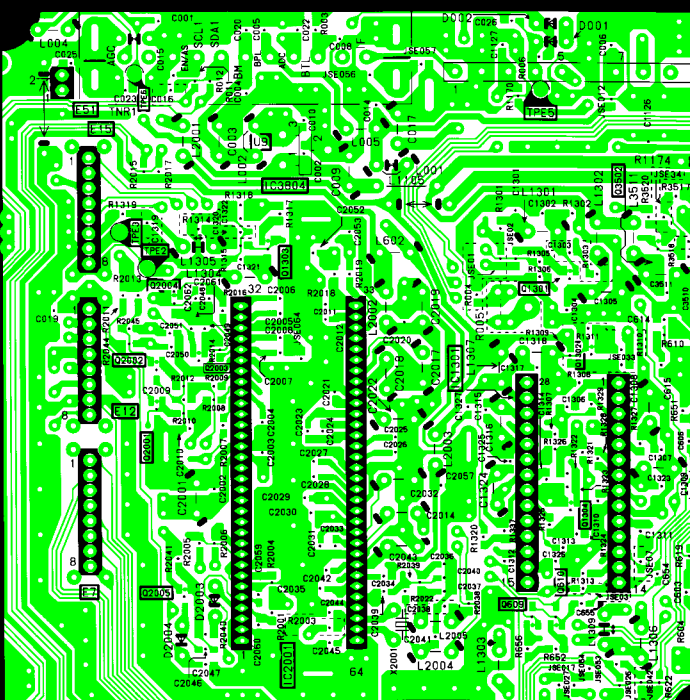

TNPA0756 (F2) ②

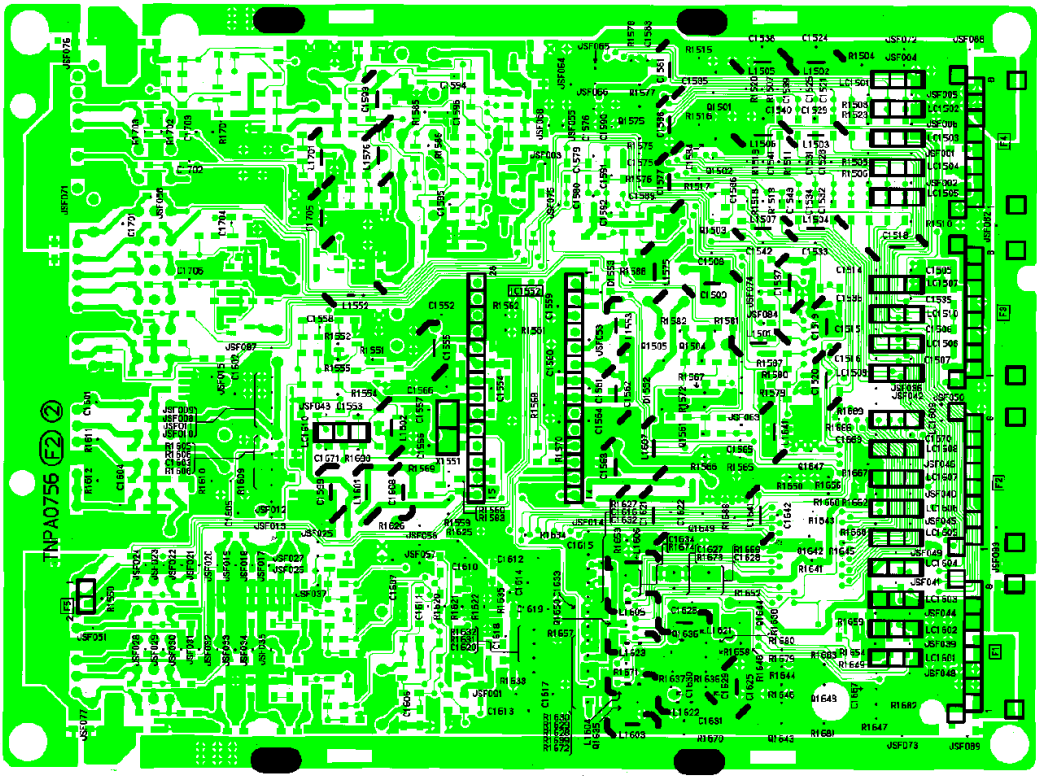

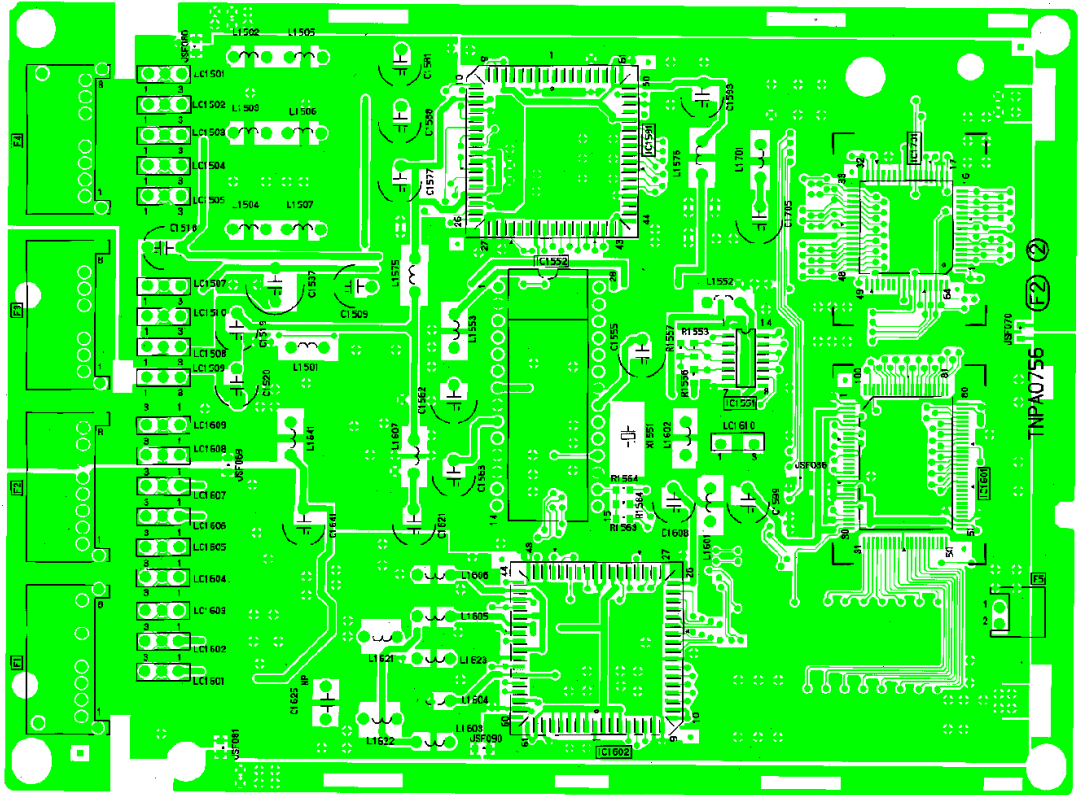

TNPA0756

15770

F2

F1

F1

F2

F3

F4

1
2
3
4
5
6
7
8
9
10
11
12
13
14
15
16
17
18
19
20
21
22
23
24
25
26
27
28
29
30
31
32
33
34
35
36
37
38
39
40
41
42
43
44
45
46
47
48
49
50
51
52
53
54
55
56
57
58
59
60
61
62
63
64
65
66
67
68
69
70
71
72
73
74
75
76
77
78
79
80
81
82
83
84
85
86
87
88
89
90
91
92
93
94
95
96
97
98
99
100

F1

F2

F3

F4

F5

LC1501
LC1502
LC1503
LC1504
LC1505
LC1506
LC1507
LC1508
LC1509
LC1510
LC1511
LC1512
LC1513
LC1514
LC1515
LC1516
LC1517
LC1518
LC1519
LC1520
LC1521
LC1522
LC1523
LC1524
LC1525
LC1526
LC1527
LC1528
LC1529
LC1530
LC1531
LC1532
LC1533
LC1534
LC1535
LC1536
LC1537
LC1538
LC1539
LC1540
LC1541
LC1542
LC1543
LC1544
LC1545
LC1546
LC1547
LC1548
LC1549
LC1550
LC1551
LC1552
LC1553
LC1554
LC1555
LC1556
LC1557
LC1558
LC1559
LC1560
LC1561
LC1562
LC1563
LC1564
LC1565
LC1566
LC1567
LC1568
LC1569
LC1570
LC1571
LC1572
LC1573
LC1574
LC1575
LC1576
LC1577
LC1578
LC1579
LC1580
LC1581
LC1582
LC1583
LC1584
LC1585
LC1586
LC1587
LC1588
LC1589
LC1590
LC1591
LC1592
LC1593
LC1594
LC1595
LC1596
LC1597
LC1598
LC1599
LC1600
LC1601
LC1602
LC1603
LC1604
LC1605
LC1606
LC1607
LC1608

C1501
C1502
C1503
C1504
C1505
C1506
C1507
C1508
C1509
C1510
C1511
C1512
C1513
C1514
C1515
C1516
C1517
C1518
C1519
C1520
C1521
C1522
C1523
C1524
C1525
C1526
C1527
C1528
C1529
C1530
C1531
C1532
C1533
C1534
C1535
C1536
C1537
C1538
C1539
C1540
C1541
C1542
C1543
C1544
C1545
C1546
C1547
C1548
C1549
C1550
C1551
C1552
C1553
C1554
C1555
C1556
C1557
C1558
C1559
C1560
C1561
C1562
C1563
C1564
C1565
C1566
C1567
C1568
C1569
C1570
C1571
C1572
C1573
C1574
C1575
C1576
C1577
C1578
C1579
C1580
C1581
C1582
C1583
C1584
C1585
C1586
C1587
C1588
C1589
C1590
C1591
C1592
C1593
C1594
C1595
C1596
C1597
C1598
C1599
C1600
C1601
C1602
C1603
C1604
C1605
C1606
C1607
C1608

L1501
L1502
L1503
L1504
L1505
L1506
L1507
L1508
L1509
L1510
L1511
L1512
L1513
L1514
L1515
L1516
L1517
L1518
L1519
L1520
L1521
L1522
L1523
L1524
L1525
L1526
L1527
L1528
L1529
L1530
L1531
L1532
L1533
L1534
L1535
L1536
L1537
L1538
L1539
L1540
L1541
L1542
L1543
L1544
L1545
L1546
L1547
L1548
L1549
L1550
L1551
L1552
L1553
L1554
L1555
L1556
L1557
L1558
L1559
L1560
L1561
L1562
L1563
L1564
L1565
L1566
L1567
L1568
L1569
L1570
L1571
L1572
L1573
L1574
L1575
L1576
L1577
L1578
L1579
L1580
L1581
L1582
L1583
L1584
L1585
L1586
L1587
L1588
L1589
L1590
L1591
L1592
L1593
L1594
L1595
L1596
L1597
L1598
L1599
L1600
L1601
L1602
L1603
L1604
L1605
L1606
L1607
L1608

R1501
R1502
R1503
R1504
R1505
R1506
R1507
R1508
R1509
R1510
R1511
R1512
R1513
R1514
R1515
R1516
R1517
R1518
R1519
R1520
R1521
R1522
R1523
R1524
R1525
R1526
R1527
R1528
R1529
R1530
R1531
R1532
R1533
R1534
R1535
R1536
R1537
R1538
R1539
R1540
R1541
R1542
R1543
R1544
R1545
R1546
R1547
R1548
R1549
R1550
R1551
R1552
R1553
R1554
R1555
R1556
R1557
R1558
R1559
R1560
R1561
R1562
R1563
R1564
R1565
R1566
R1567
R1568
R1569
R1570
R1571
R1572
R1573
R1574
R1575
R1576
R1577
R1578
R1579
R1580
R1581
R1582
R1583
R1584
R1585
R1586
R1587
R1588
R1589
R1590
R1591
R1592
R1593
R1594
R1595
R1596
R1597
R1598
R1599
R1600
R1601
R1602
R1603
R1604
R1605
R1606
R1607
R1608

IC1501
IC1502
IC1503
IC1504
IC1505
IC1506
IC1507
IC1508
IC1509
IC1510
IC1511
IC1512
IC1513
IC1514
IC1515
IC1516
IC1517
IC1518
IC1519
IC1520
IC1521
IC1522
IC1523
IC1524
IC1525
IC1526
IC1527
IC1528
IC1529
IC1530
IC1531
IC1532
IC1533
IC1534
IC1535
IC1536
IC1537
IC1538
IC1539
IC1540
IC1541
IC1542
IC1543
IC1544
IC1545
IC1546
IC1547
IC1548
IC1549
IC1550
IC1551
IC1552
IC1553
IC1554
IC1555
IC1556
IC1557
IC1558
IC1559
IC1560
IC1561
IC1562
IC1563
IC1564
IC1565
IC1566
IC1567
IC1568
IC1569
IC1570
IC1571
IC1572
IC1573
IC1574
IC1575
IC1576
IC1577
IC1578
IC1579
IC1580
IC1581
IC1582
IC1583
IC1584
IC1585
IC1586
IC1587
IC1588
IC1589
IC1590
IC1591
IC1592
IC1593
IC1594
IC1595
IC1596
IC1597
IC1598
IC1599
IC1600
IC1601
IC1602
IC1603
IC1604
IC1605
IC1606
IC1607
IC1608

JP1501
JP1502
JP1503
JP1504
JP1505
JP1506
JP1507
JP1508
JP1509
JP1510
JP1511
JP1512
JP1513
JP1514
JP1515
JP1516
JP1517
JP1518
JP1519
JP1520
JP1521
JP1522
JP1523
JP1524
JP1525
JP1526
JP1527
JP1528
JP1529
JP1530
JP1531
JP1532
JP1533
JP1534
JP1535
JP1536
JP1537
JP1538
JP1539
JP1540
JP1541
JP1542
JP1543
JP1544
JP1545
JP1546
JP1547
JP1548
JP1549
JP1550
JP1551
JP1552
JP1553
JP1554
JP1555
JP1556
JP1557
JP1558
JP1559
JP1560
JP1561
JP1562
JP1563
JP1564
JP1565
JP1566
JP1567
JP1568
JP1569
JP1570
JP1571
JP1572
JP1573
JP1574
JP1575
JP1576
JP1577
JP1578
JP1579
JP1580
JP1581
JP1582
JP1583
JP1584
JP1585
JP1586
JP1587
JP1588
JP1589
JP1590
JP1591
JP1592
JP1593
JP1594
JP1595
JP1596
JP1597
JP1598
JP1599
JP1600
JP1601
JP1602
JP1603
JP1604
JP1605
JP1606
JP1607
JP1608

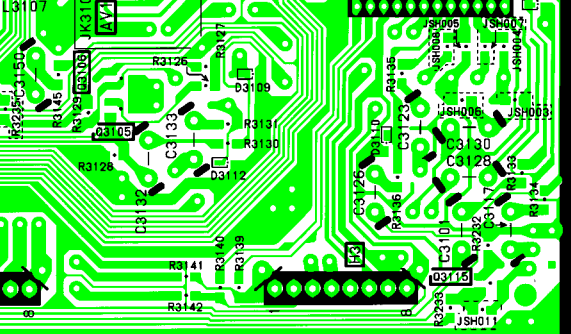
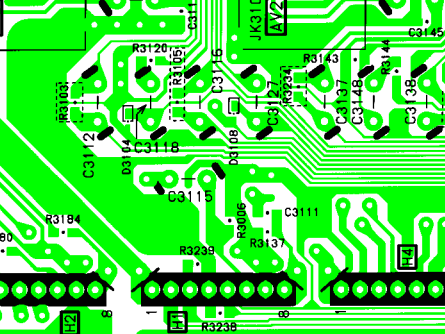
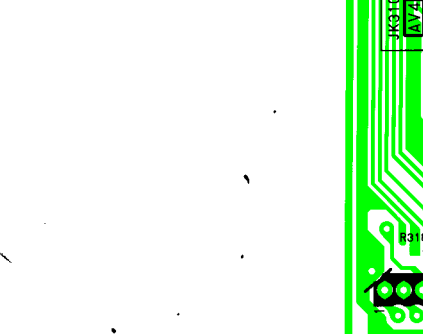
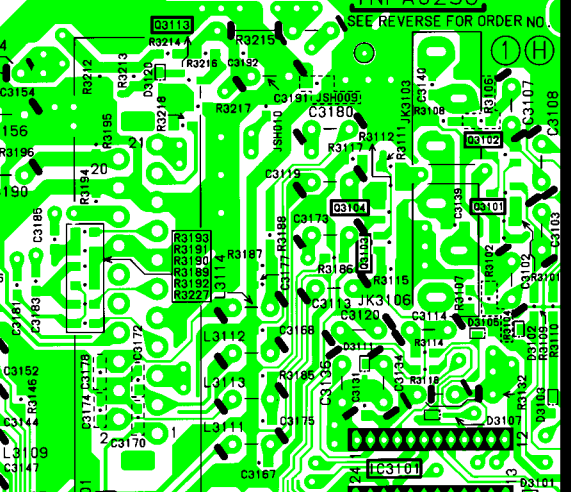
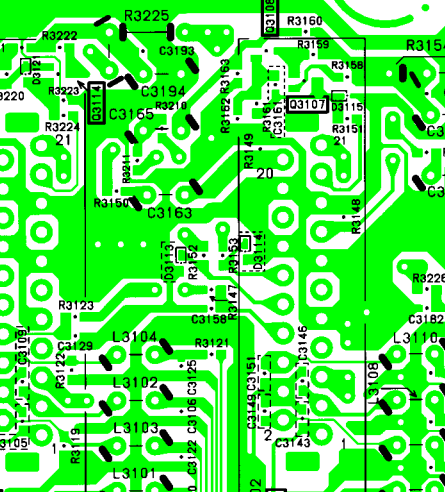
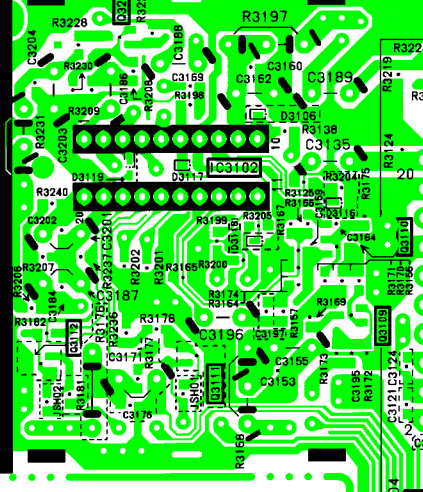
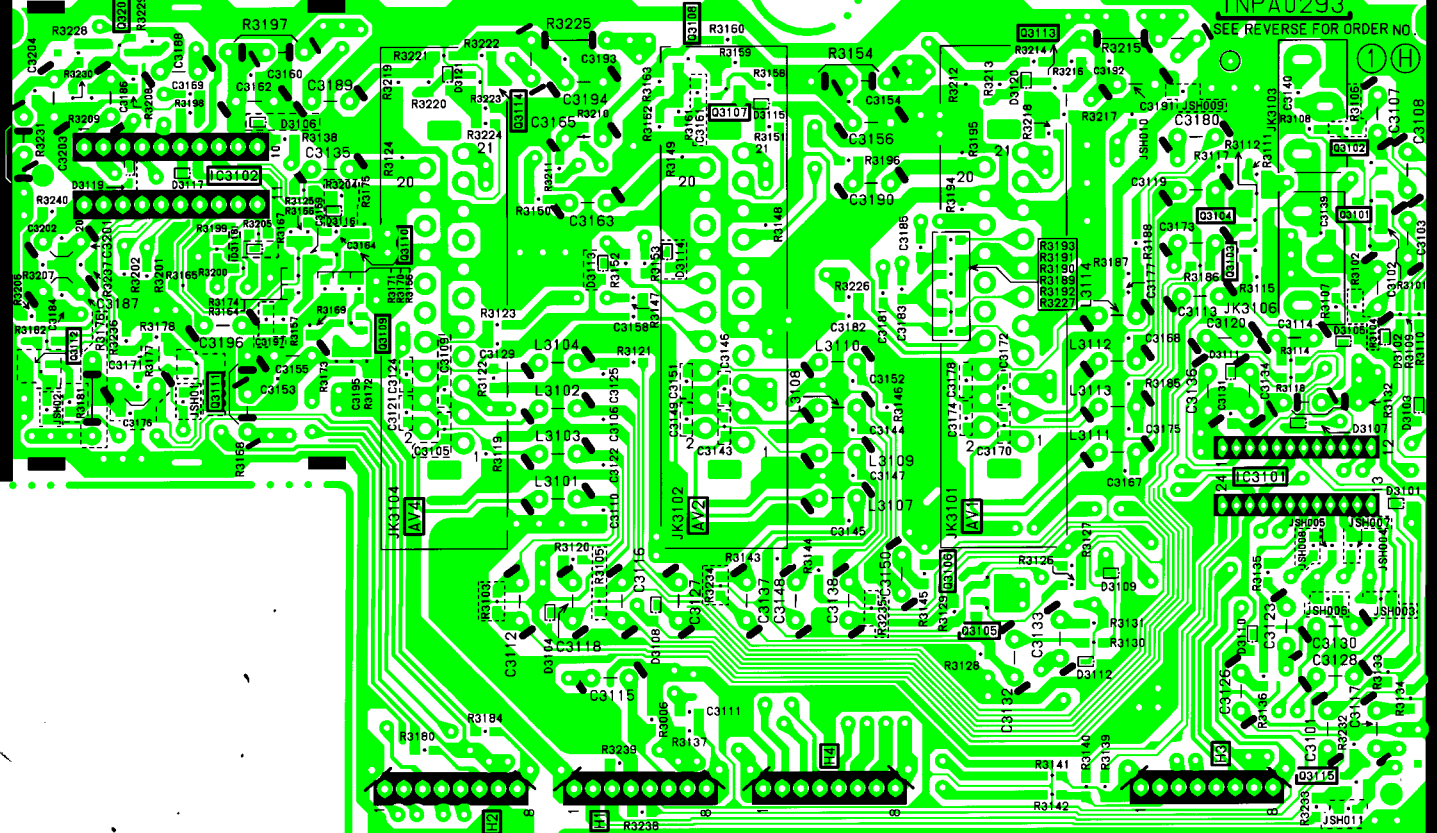

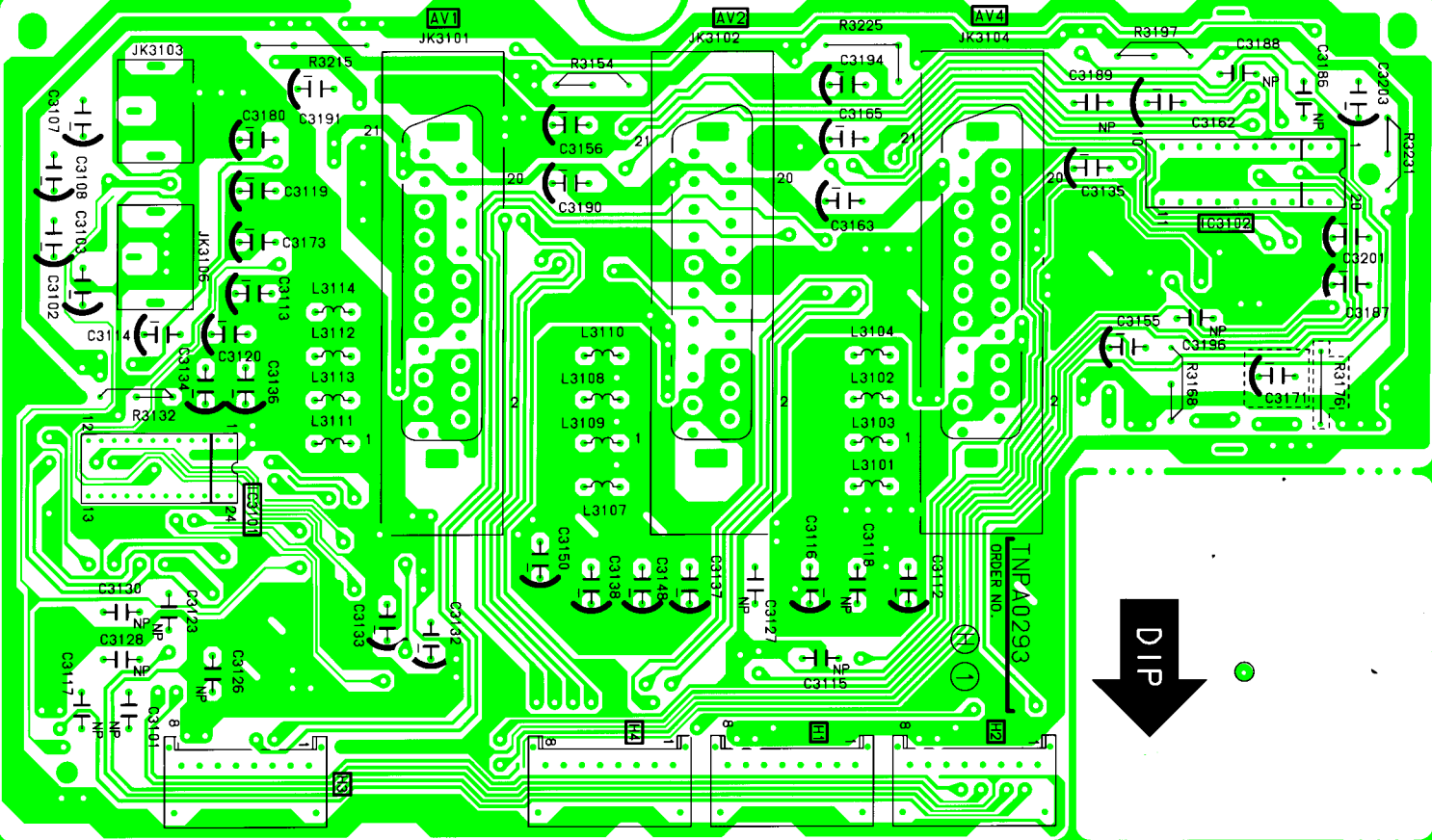

TINPA0293

ORDER NO.



DIP

